

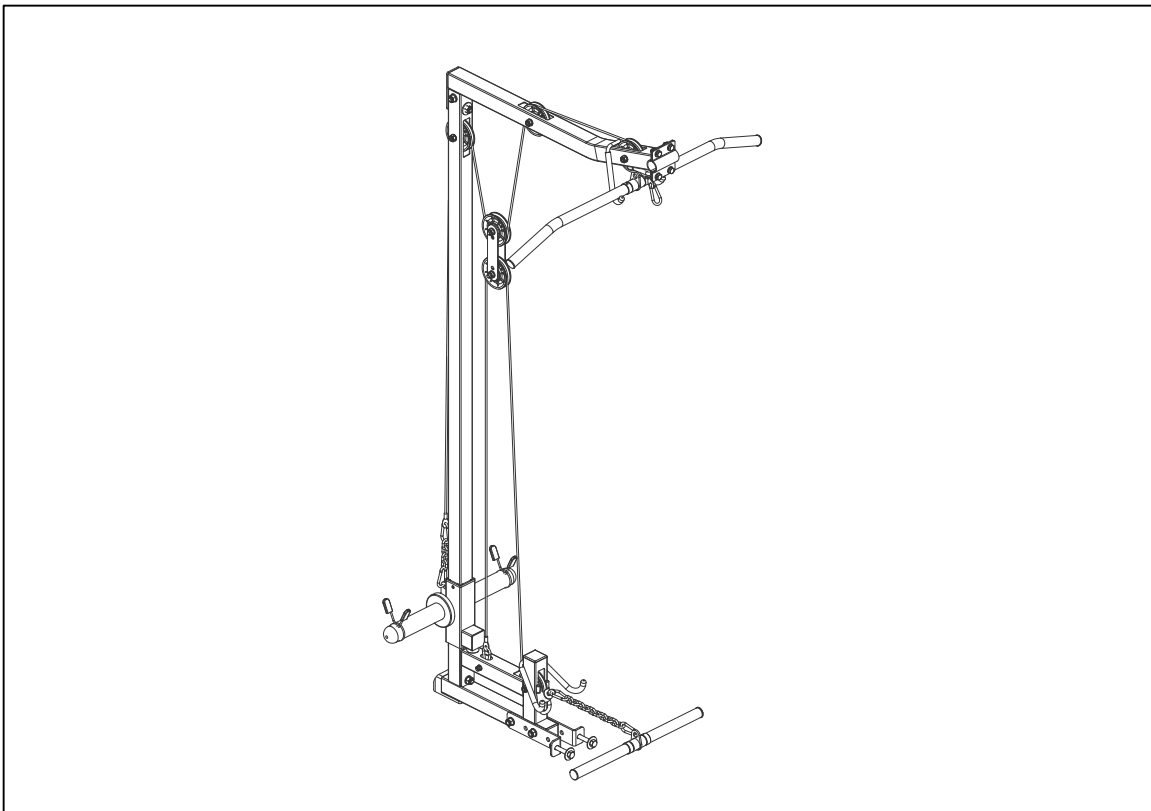

# LAT PULLDOWN ATTACHMENT

## SF-XF9927

### USER MANUAL



**IMPORTANT!** Please retain owner's manual for maintenance and adjustment instructions. Your satisfaction is very important to us, **PLEASE DO NOT RETURN UNTIL YOU HAVE CONTACTED US:** [support@sunnyhealthfitness.com](mailto:support@sunnyhealthfitness.com) or 1-877-90SUNNY (877-907-8669).



[WWW.SUNNYHEALTHFITNESS.COM](http://WWW.SUNNYHEALTHFITNESS.COM)

# **IMPORTANT SAFETY INFORMATION**

We thank you for choosing our product. To ensure your safety and health, please use this equipment correctly. It is important to read this entire manual before assembling and using the equipment. Safe and effective use can only be achieved if the equipment is assembled, maintained, and used properly. It is your responsibility to ensure that all users of the equipment are informed of all warnings and precautions.

1. Before starting any exercise program, you should consult your physician to determine if you have any medical or physical conditions that could put your health and safety at risk or prevent you from using the equipment properly. Your physician's advice is essential if you are taking medication that affects your heart rate, blood pressure, or cholesterol level.
2. Be aware of your body's signals. Incorrect or excessive exercise can damage your health. Stop exercising if you experience any of the following symptoms: pain, tightness in your chest, irregular heartbeat, shortness of breath, lightheadedness, dizziness, or feelings of nausea. If you do experience any of these conditions, you should consult your physician before continuing with your exercise program.
3. Keep children and pets away from the equipment. The equipment is designed for adult use only.
4. Use the equipment on a solid, flat level surface with a protective cover for your floor or carpet. To ensure safety, the equipment should have at least 4 feet (120 cm) of free space all around it.
5. Ensure that all nuts and bolts are securely tightened before using the equipment. The safety of the equipment can only be maintained if it is regularly examined for damage and/or wear and tear.
6. Always use the equipment as indicated. If you find any defective components while assembling or checking the equipment, or if you hear any unusual noises coming from the equipment during exercise, discontinue use of the equipment immediately and do not use until the problem has been rectified.
7. Wear suitable clothing while using the equipment. Avoid wearing loose clothing that may become entangled in the equipment.
8. Do not place fingers or objects into the moving parts of the equipment.
9. The maximum weight capacity of this unit is 200 lbs (90 kgs).
10. The equipment is not suitable for therapeutic use.
11. To avoid bodily injury and/or damage to the product or property, proper lifting and moving are required.
12. Your product is intended for use in cool and dry conditions. You should avoid storage in extreme cold, hot or damp areas as this may lead to corrosion and other related problems.
13. This equipment is designed for indoor and home use only; it is not intended for commercial use.

# EXPLODED DIAGRAM

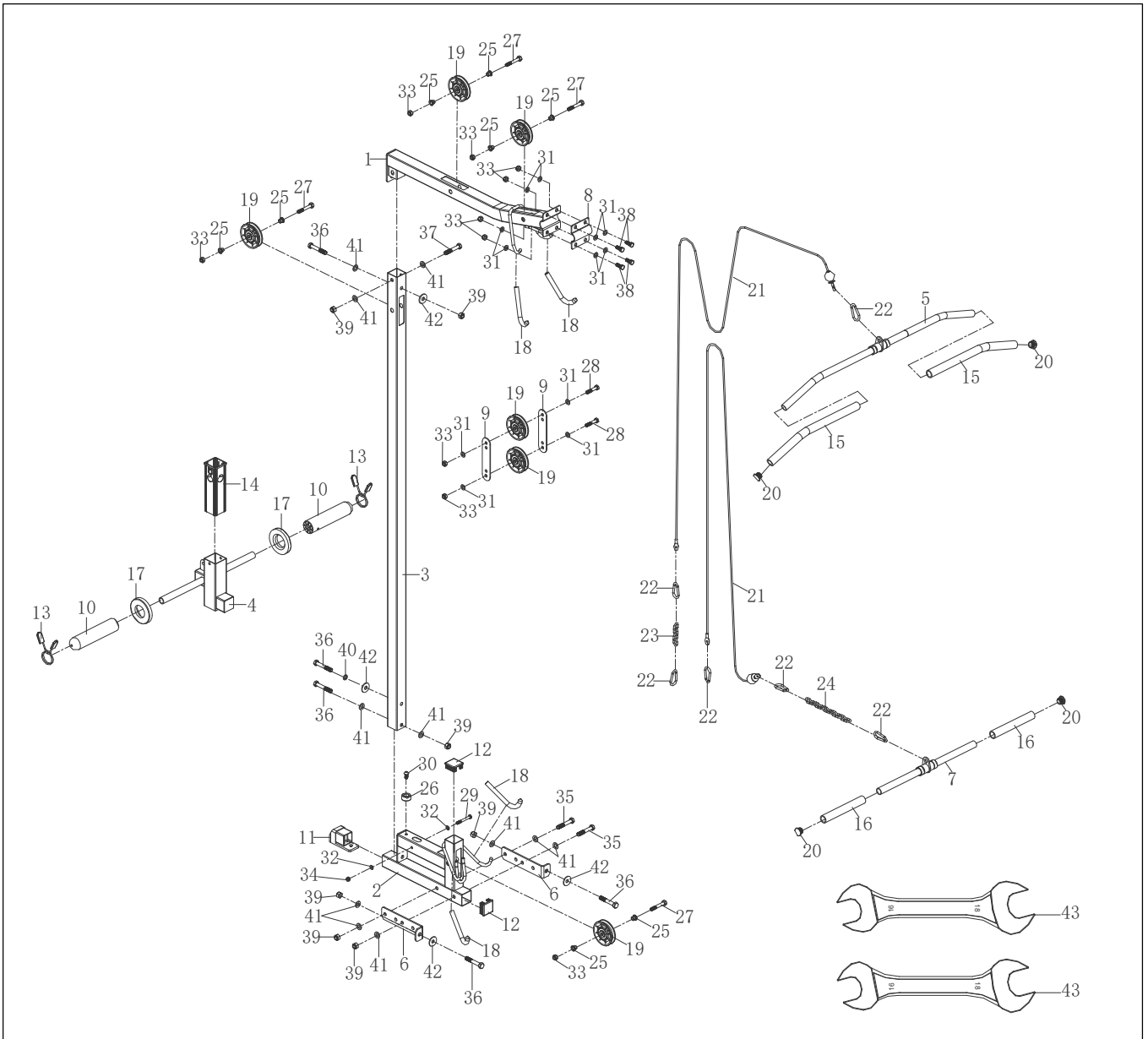

# HARDWARE PACKAGE

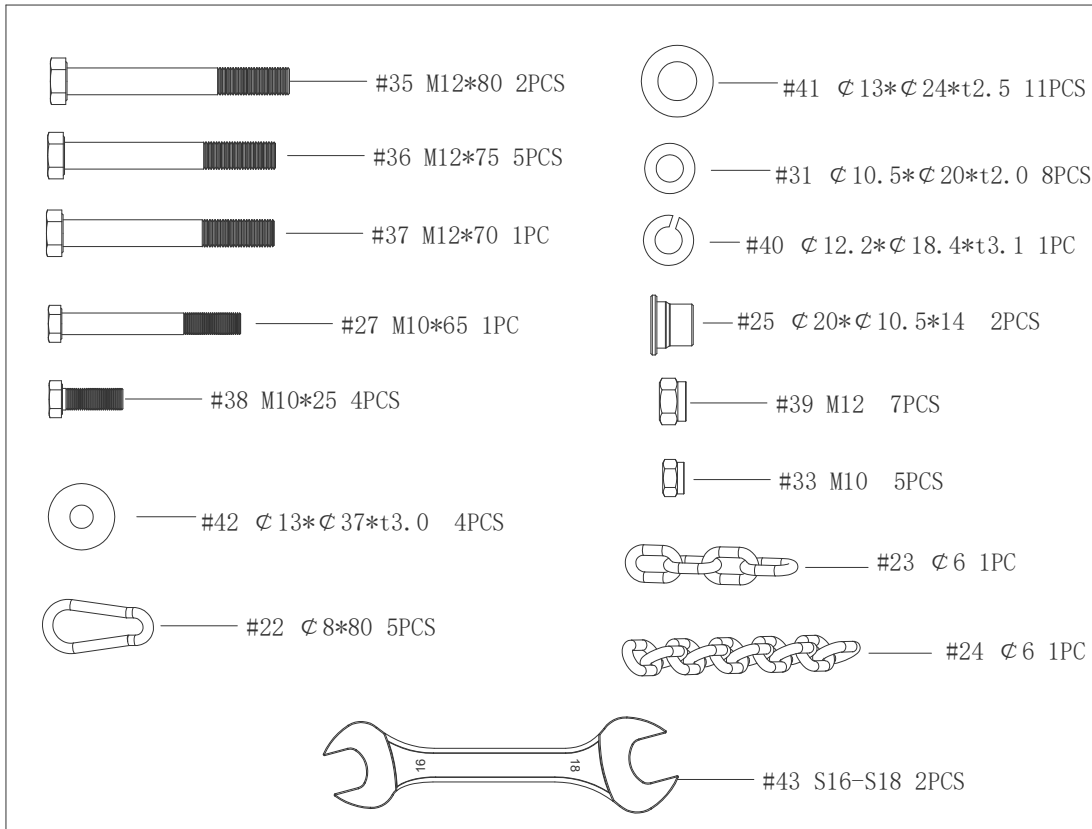

## PARTS LIST

No.	Description	Spec.	Qty.	No.	Description	Spec.	Qty.
1	Top Connecting Frame		1	23	Section 4 Chain	∅ 6	1
2	Bottom Connecting Frame		1	24	Section 10 Chain	∅ 6	1
3	Upright Post		1	25	Alloy Wrap	∅ 20*∅ 10.5*14	8
4	Slide Rest		1	26	Crash Pad	∅ 35*∅ 32*15	1
5	High Bar		1	27	Hexagon Bolt	M10*65	4
6	Bottom Frame Fixing Plate		2	28	Hexagon Bolt	M10*50	2
7	Low Bar		1	29	Hexagon Bolt	M8*65	1
8	Top Connection Plate		1	30	Bolt	M10*20	1
9	Pulley Connection Plate		2	31	Flat Washer	∅ 10.5*∅ 20*t2.0	12
10	Barbell Support Rod	∅ 100*∅ 48*200	2	32	Flat Washer	∅ 8.4*∅ 20*t1.5	2
11	End Cap	115*50	1	33	Nut	M10	10
12	Square End Cap	50*50*t5.0	2	34	Nut	M8	1
13	Spring Clip	∅ 48	2	35	Hexagon Bolt	M12*80	2
14	Bushing	60*60*205	1	36	Hexagon Bolt	M12*75	5
15	Foam Grip	∅ 24*∅ 32*460	2	37	Hexagon Bolt	M12*70	1
16	Foam Grip	∅ 24*∅ 32*210	2	38	Hexagon Bolt	M10*25	4
17	Crash Pad	∅ 80*∅ 50*16	2	39	Nut	M12	7
18	Handlebar Grip	∅ 9*∅ 15*150	4	40	Spring Washer	∅ 12.2*∅ 18.4*t3.1	1
19	Pulley Combination	∅ 96*∅ 10.5*26	6	41	Flat Washer	∅ 13*∅ 24*t2.5	11
20	Round End Cap	∅ 25*t2.0	4	42	Flat Big Washer	∅ 13*∅ 37*t3.0	4
21	Wire Rope Assembly	∅ 5*2670	2	43	Open End Wrench	S16-S18	2
22	Hoist Hook	∅ 8*80	6				

### Ordering Replacement Parts (U.S. and Canadian Customers only)

Please provide the following information in order for us to accurately identify the part(s) needed:

- ✓ The model number (found on cover of manual)
- ✓ The product name (found on cover of manual)
- ✓ The part number found on the “EXPLODED DIAGRAM” and “PARTS LIST” (found near the front of the manual)

Please contact us at [support@sunnyhealthfitness.com](mailto:support@sunnyhealthfitness.com) or 1-877-90SUNNY (877-907-8669).

# ASSEMBLY INSTRUCTIONS

We value your experience using Sunny Health and Fitness products. For assistance with parts or troubleshooting, please contact us at [support@sunnyhealthfitness.com](mailto:support@sunnyhealthfitness.com) or 1-877-90SUNNY (877-907-8669).

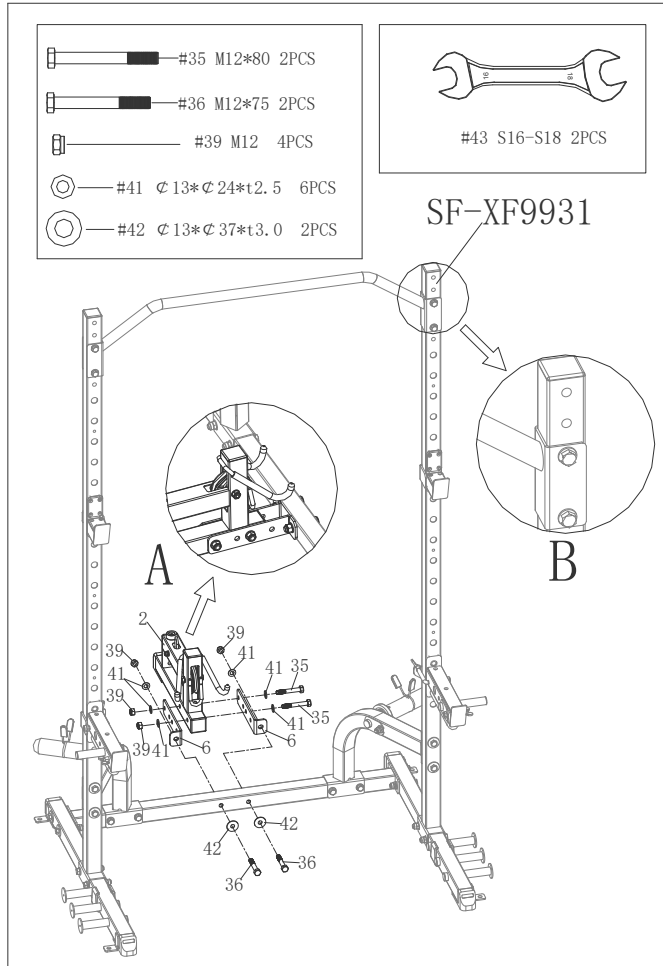

## STEP 1:

Secure the pull up bar of SF-XF9931 on position B as showed.

Attach **Bottom Connecting Frame (No. 2)** onto 2 **Bottom Frame Fixing Plates (No. 6)** using 2 **Hexagon Bolts (No. 35)**, 2 **Nuts (No. 39)** and 4 **Flat Washers (No. 41)**. Secure with 2 **Open End Wrenches (No. 43)**. Do not tighten the 2 **Hexagon Bolts (No. 35)** during this step. The connecting hole location is shown in diagram A.

Attach 2 **Bottom Frame Fixing Plates (No. 6)** onto Bottom Connecting Frame of SF-XF9931 using 2 **Hexagon Bolts (No. 36)**, 2 **Nuts (No. 39)**, 2 **Flat Washers (No. 41)** and 2 **Flat Big Washers (No. 42)**. Secure with 2 **Open End Wrenches (No. 43)**. Do not tighten the 2 **Nuts (No. 39)** during this step.

We value your experience using Sunny Health and Fitness products. For assistance with parts or troubleshooting, please contact us at [support@sunnyhealthfitness.com](mailto:support@sunnyhealthfitness.com) or 1-877-90SUNNY (877-907-8669).

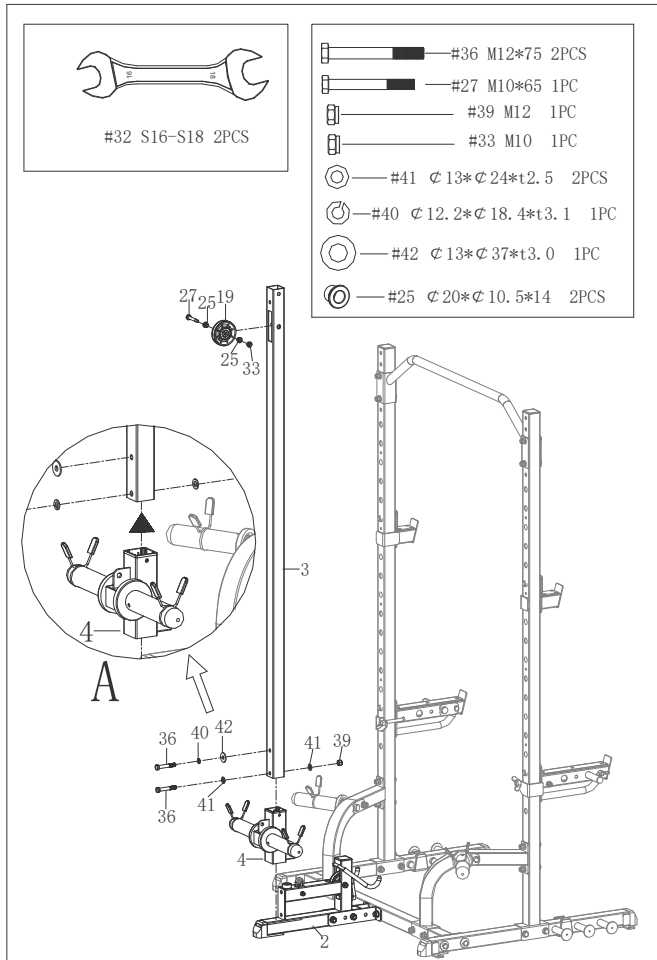

## STEP 2:

Assemble **Slide Rest (No. 4)** upward through **Upright Post (No. 3)**, see diagram A.

Attach **Upright Post (No. 3)** onto **Bottom Connecting Frame (No. 2)** Using 2 **Hexagon Bolts (No. 36)**, 1 **Nut (No. 39)**, 2 **Flat Washers (No. 41)**, 1 **Flat Big Washer (No. 42)** and 1 **Spring Washer (No. 40)**. Secure with 2 **Open End Wrenches (No. 43)**. Do not tighten the **Nut (No. 39)** during this step.

Attach **Pulley Combination (No. 19)** onto **Upright Post (No. 3)** using 1 **Hexagon Bolt (No. 27)**, 2 **Alloy Wraps (No. 25)** and 1 **Nut (No. 33)**. Tighten and secure with 2 **Open End Wrenches (No. 43)**.

We value your experience using Sunny Health and Fitness products. For assistance with parts or troubleshooting, please contact us at [support@sunnyhealthfitness.com](mailto:support@sunnyhealthfitness.com) or 1-877-90SUNNY (877-907-8669).

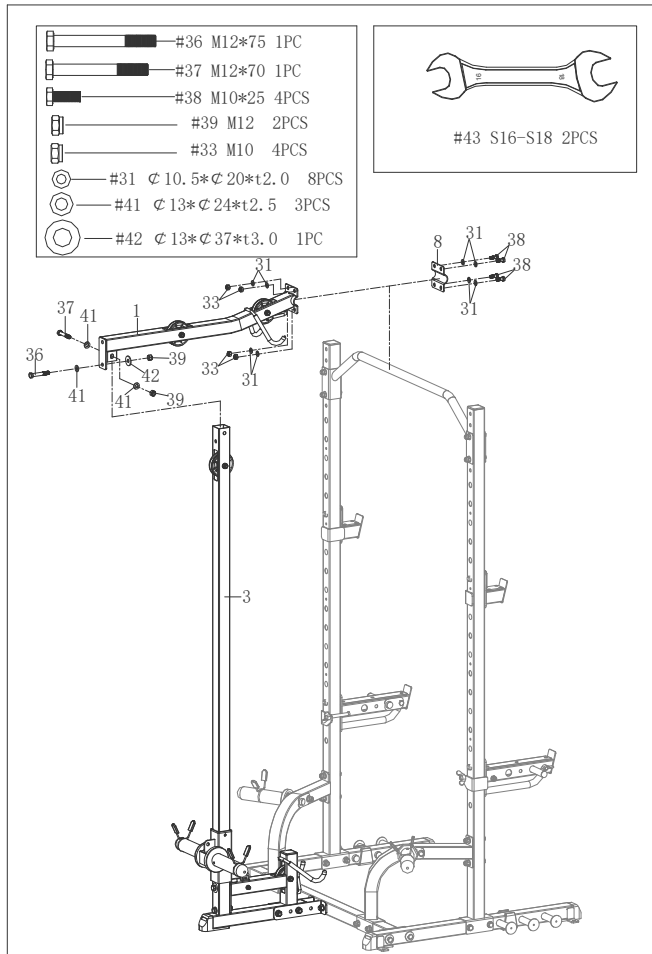

### STEP 3:

Insert **Top Connecting Frame (No. 1)** onto **Upright Post (No. 3)** using 1 **Hexagon Bolt (No. 36)**, 1 **Hexagon Bolt (No. 37)**, 2 **Nuts (No. 39)**, 3 **Flat Washers (No. 41)** and 1 **Flat Big Washer (No. 42)**. Secure with 2 **Open End Wrenches (No. 43)**. Do not tighten the 2 **Nuts (No. 39)** during this step.

Attach **Top Connecting Frame (No. 1)** and **Top Connection Plate (No. 8)** onto the Pull Up Bar of SF-XF9931 using 4 **Hexagon Bolts (No. 38)**, 4 **Nuts (No. 33)** and 8 **Flat Washers (No. 31)**. Secure with 2 **Open End Wrenches (No. 43)**.

Adjust the center of the equipment and lock the equipment tightly.

Now you can tighten all the **Nuts (No. 39)** from **STEP 1 & STEP 2 & STEP 3** and all the **Hexagon Bolts (No. 35)** from **STEP 1**.

We value your experience using Sunny Health and Fitness products. For assistance with parts or troubleshooting, please contact us at [support@sunnyhealthfitness.com](mailto:support@sunnyhealthfitness.com) or 1-877-90SUNNY (877-907-8669).

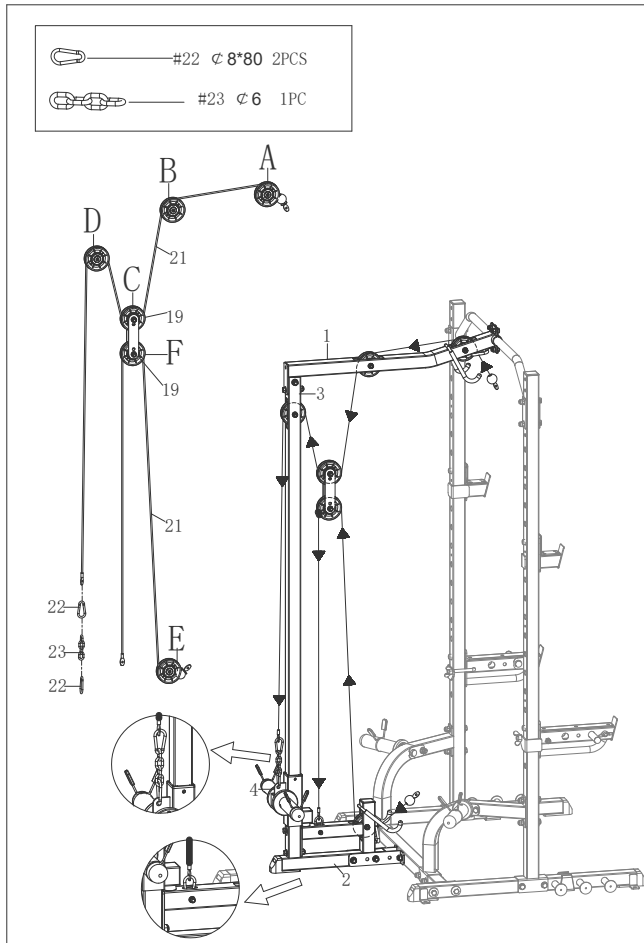

#### STEP 4:

Pass 1 Wire Rope Assembly (No. 21) through Pulley Combination (No. 19) A-B-C-D in sequence and then attach 2 Hoist Hooks (No. 22) and 1 Section 4 Chain (No. 23) onto Slide Rest (No. 4).

Pass 1 Wire Rope Assembly (No. 21) through Pulley Combination (No. 19) E-F in order and then attach onto Bottom Connecting Frame (No. 2).

Adjust the connection length of 2 Hoist Hooks (No. 22) and Section 4 Chain (No. 23) and change the tension of the wire rope.

We value your experience using Sunny Health and Fitness products. For assistance with parts or troubleshooting, please contact us at [support@sunnyhealthfitness.com](mailto:support@sunnyhealthfitness.com) or 1-877-90SUNNY (877-907-8669).

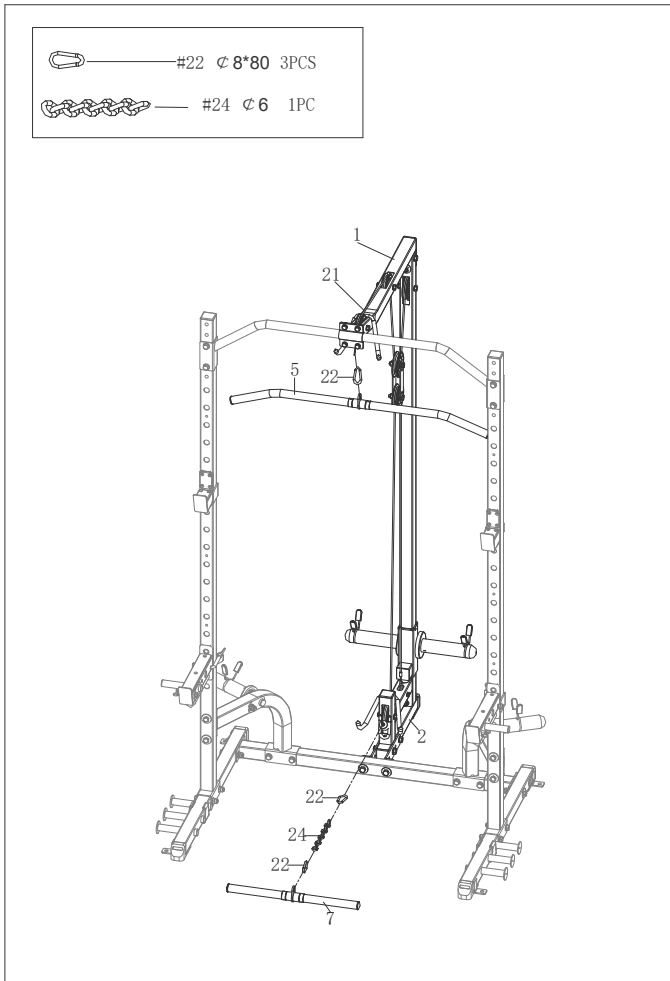

### STEP 5:

Attach **High Bar (No. 5)** onto the **Wire Rope Assembly (No. 21)** on the **Top Connecting Frame (No. 1)** with 1 **Hoist Hook (No. 22)**.

Attach **Low Bar (No. 7)** to the **Bottom Connecting Frame (No. 2)** with 2 **Hoist Hooks (No. 22)** and 1 **Section 10 Chain (No. 24)**.

*The assembly is complete!*

# INSTALLATION INSTRUCTIONS

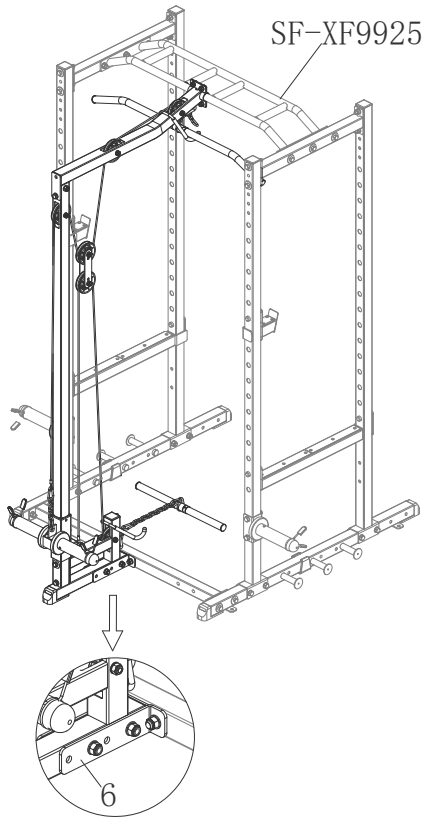

The installation mode of SF-XF9927 and SF-XF9925 is the same as that of SF-XF9927 and SF-XF9931. Please note the installation hole of 2 **Bottom Frame Fixing Plates (No. 6)**.

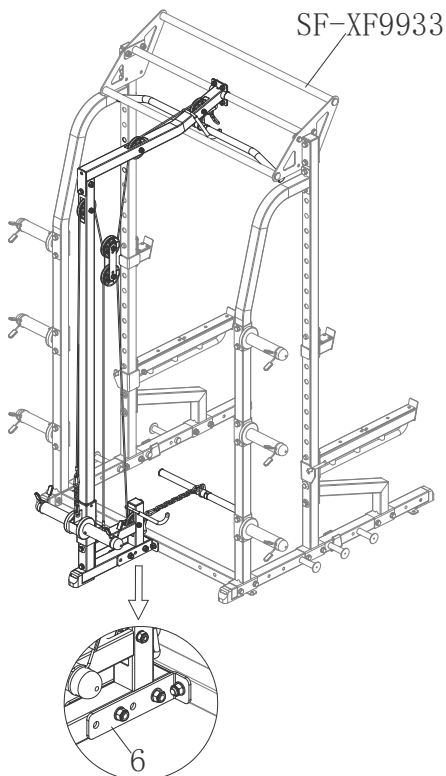

The installation mode of SF-XF9927 and SF-XF9933 is the same as that of SF-XF9927 and SF-XF9931. Please note the installation hole of 2 **Bottom Frame Fixing Plates (No. 6)**.

# **MAINTENANCE INSTRUCTIONS**

## **DAILY MAINTENANCE**

Inspect and tighten all parts regularly. (Nuts, Bolts, Rubber Pads, Steel Brackets, etc.)

Replace any worn or torn parts immediately.

Check and ensure the equipment is leveled at all time.

Check and tighten all adjustment pins/knobs regularly.

## **WEEKLY MAINTENANCE**

Use damp cloth on plastic parts only, use dry cloth on metal frames.

Inspect the metal frame structure of the equipment.

## **DOWNLOAD SUNNYFIT - FOR HOME FITNESS**



SunnyFit is an all-in-one home fitness app designed to empower users of all levels to achieve their fitness goals. Discover over 1,000 free on-demand workout video courses crafted by certified trainers, tailored for various exercise equipment such as indoor bikes, treadmills, rowers, ellipticals, dumbbells, bodyweight, and even resistance band exercises. Whether you have equipment or not, SunnyFit offers the perfect workout for every fitness level and preference. You can enjoy a collection of over 300 free workout courses that require nothing more than your body and the SunnyFit app.

**CONNECT**  
with us

## DOWNLOAD

Track your fitness progress & join  
**FREE** workout courses!

Download  **SUNNYFIT** today!



---

## FOLLOW

Find us on social media @sunnyhealthfitness

 @sunnyhealthfitness

 @sunnyhealthandfitness

 @sunnyhealthfit

 /sunnyhealthfitness

 /sunnyhealthfitness

 /sunnyhealthandfitness

[www.sunnyhealthfitness.com](http://www.sunnyhealthfitness.com)