

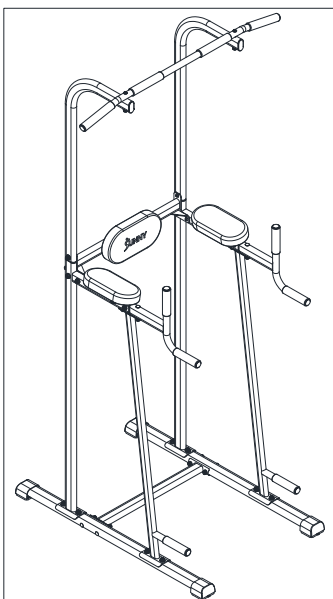

**MULTI-FUNCTION POWER TOWER WITH DIP
STATION, PULL UP BAR, AND CORE WORKOUT
SF-XF924016
USER MANUAL**



English, Page 1~9

IMPORTANT! Please retain owner's manual for maintenance and adjustment instructions. Your satisfaction is very important to us, **PLEASE DO NOT RETURN UNTIL YOU HAVE CONTACTED US:**

IMPORTANT SAFETY INFORMATION

We thank you for choosing our product. To ensure your safety and health, please use this equipment correctly. It is important to read this entire manual before assembling and using the equipment. Safe and effective use can only be achieved if the equipment is assembled, maintained, and used properly. It is your responsibility to ensure that all users of the equipment are informed of all warnings and precautions.

1. Before starting any exercise program, you should consult your physician to determine if you have any medical or physical condition that could put your health and safety at risk or prevent you from using the equipment properly. Your physician's advice is essential if you are taking medication that affects your heart rate, blood pressure or cholesterol level.
2. Be aware of your body's signals. Incorrect or excessive exercise can damage your health. Stop exercising if you experience any of the following symptoms: pain, tightness in your chest, irregular heartbeat, shortness of breath, lightheadedness, dizziness, or feelings of nausea. If you do experience any of these conditions, you should consult your physician before continuing with your exercise program.
3. Keep children and pets away from the equipment. The equipment is designed for adult use only.
4. Use the equipment on a solid, flat level surface with a protective cover for your floor or carpet. To ensure safety, the equipment should have at least 2 feet (60 cm) of free space all around it.
5. Ensure that all nuts and bolts are securely tightened before using the equipment. The safety of the equipment can only be maintained if it is regularly examined for damage and/or wear and tear.
6. Always use the equipment as indicated. If you find any defective components while assembling or checking the equipment, or if you hear any unusual noises coming from the equipment during exercise, discontinue use of the equipment immediately and do not use until the problem has been rectified.
7. Wear suitable clothing while using the equipment. Avoid wearing loose clothing that may become entangled in the equipment.
8. Do not place fingers or objects into the moving parts of the equipment.
9. The maximum weight capacity of this unit is 300 lbs (135kgs).
10. The equipment is not suitable for therapeutic use.
11. To avoid bodily injury and/or damage to the product or property, proper lifting and moving are required.
12. Your product is intended for use in cool and dry conditions. You should avoid storage in extremely cold, hot or damp areas as this may lead to corrosion and other related problems.
13. This equipment is designed for indoor and home use only; it is not intended for commercial use.

RE-ASSEMBLY CHECK LIST

Before you start to assemble, please make sure all parts are included.

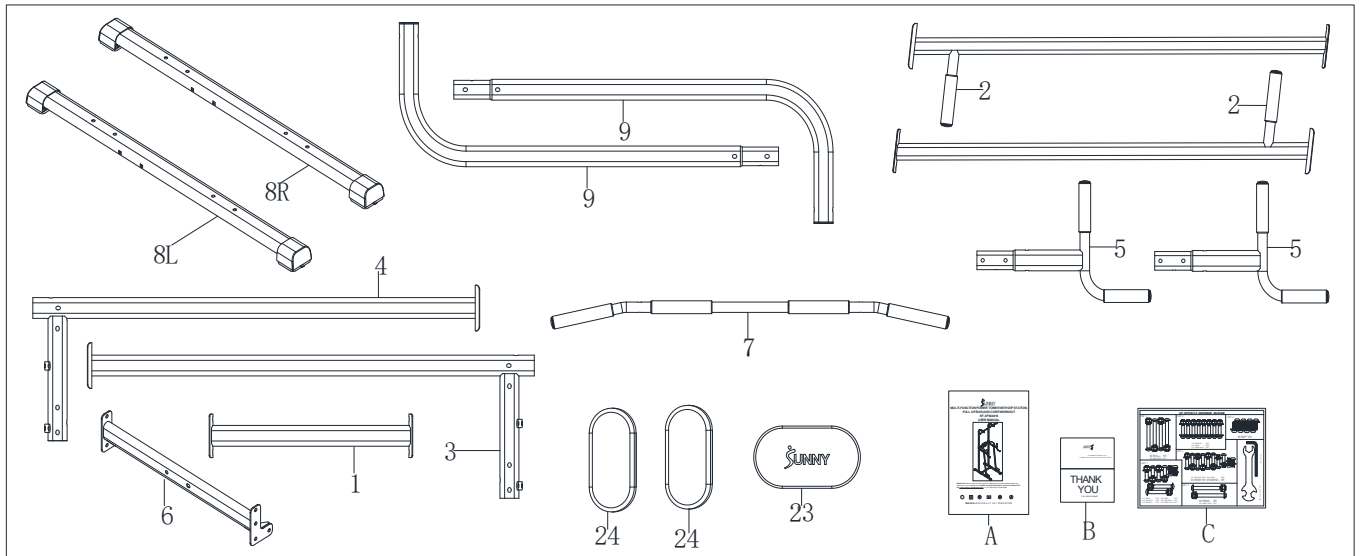

No.	Description	Spec.	Qty.
1	Bottom Connecting Tube		1
2	Front Support Tube		2
3	Left Support Tube		1
4	Right Support Tube		1
5	Elbow Support Tube		2
6	Middle Connecting Tube		1
7	Upper Frame		1
8L	Left Bottom Tube		1

No.	Description	Spec.	Qty.
8R	Right Bottom Tube		1
9	Upper Support Tube		2
23	Back Cushion	280*150*40	1
24	Hand Cushion	250*120*40	2
A	Manual		1
B	Thank You Card		1
C	Hardware Package		1

HARDWARE PACKAGE

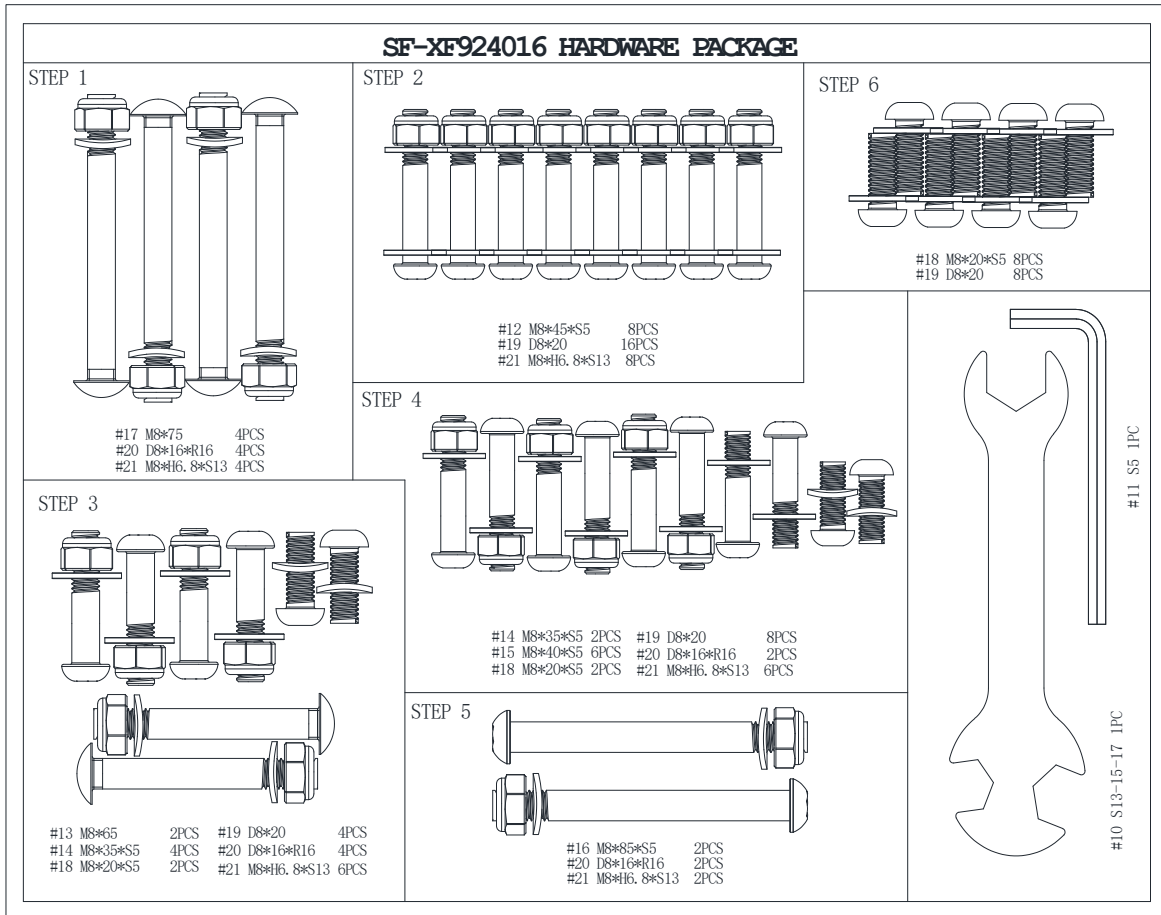

Ordering Replacement Parts (U.S. and Canadian Customers only)

Please provide the following information in order for us to accurately identify the part(s) needed:

- ✓ The model number (found on cover of manual)
- ✓ The product name (found on cover of manual)
- ✓ The part number found on the “EXPLODED DIAGRAM” (page 46) and “PARTS LIST” (page 9)

ASSEMBLY INSTRUCTIONS

We value your experience using Sunny Health and Fitness products. For assistance with parts or troubleshooting, please contact us

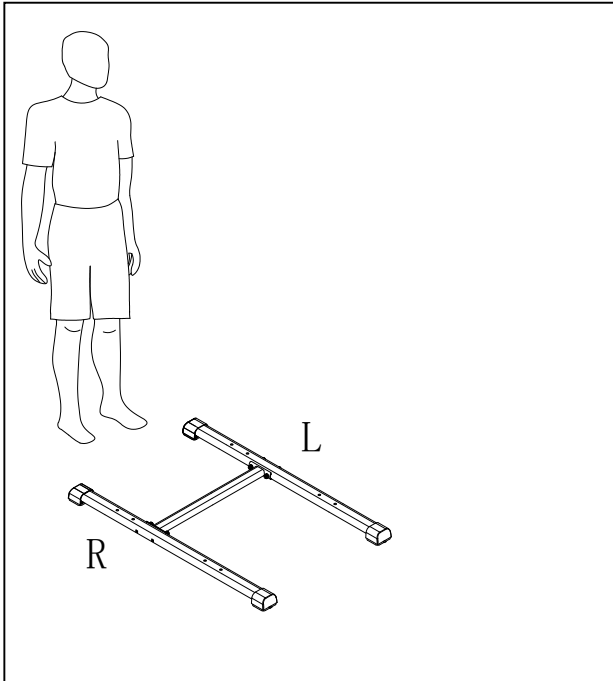

STEP 1:

NOTE: The **Left Bottom Tube (No. 8L)** is marked "L" and the **Right Bottom Tube (No. 8R)** is marked "R".

Attach the **Left & Right Bottom Tubes (No. 8L & No. 8R)** onto the **Bottom Connecting Tube (No. 1)** with 4 **Square Neck Bolts (No. 17)**, 4 **Curved Washers (No. 20)**, and 4 **Lock Nuts (No. 21)**. Secure with the **Spanner (No. 10)**.

NOTE: Do not tighten the 4 **Square Neck Bolts (No. 17)** during this step.

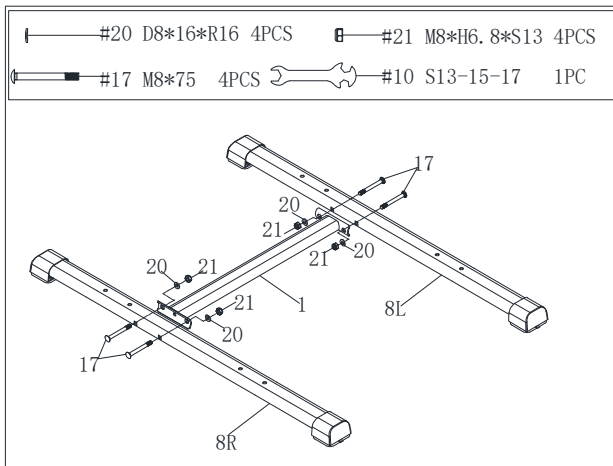

We value your experience using Sunny Health and Fitness products. For assistance with parts or troubleshooting, please contact us

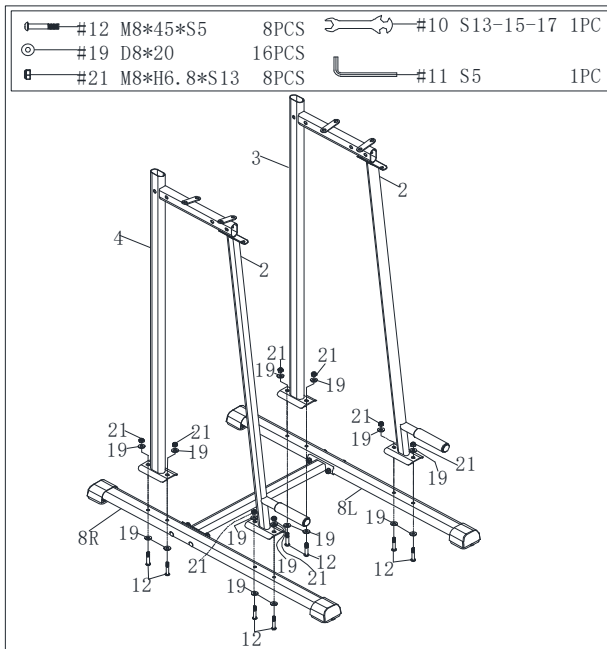

STEP 2:

NOTE: The Left Support Tube (No. 3) is marked “L” and the Right Support Tube (No. 4) is marked “R”.

Attach 1 Front Support Tube (No. 2) and the Left Support Tube (No. 3) onto the Left Bottom Tube (No. 8L) with 4 Hexagonal Bolts (No. 12), 8 Flat Washers (No. 19) and 4 Lock Nuts (No. 21). Secure with the Spanner (No.10) and the Allen Wrench (No. 11).

Attach 1 Front Support Tube (No. 2) and the Right Support Tube (No. 4) onto the Right Bottom Tube (No. 8R) with 4 Hexagonal Bolts (No. 12), 8 Flat Washers (No. 19) and 4 Lock Nuts (No. 21). Secure with the Spanner (No. 10) and the Allen Wrench (No. 11).

NOTE: Do not tighten the 8 Hexagonal Bolts (No. 12) during this step.

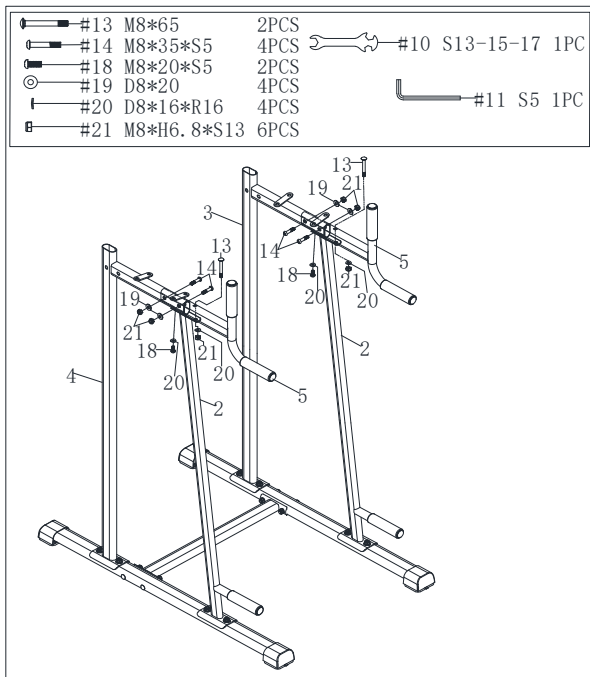

STEP 3:

Attach 1 Elbow Support Tube (No. 5) and the Front Support Tube (No. 2) onto the Left Support Tube (No. 3) with 1 Square Neck Bolt (No.13), 2 Hexagonal Bolts (No. 14), 1 Hexagonal Bolt (No. 18), 2 Flat Washers (No. 19), 2 Curved Washers (No. 20) and 3 Lock Nuts (No. 21). Secure with the Spanner (No. 10) and the Allen Wrench (No. 11).

Attach 1 Elbow Support Tube (No. 5) and the Front Support Tube (No. 2) onto the Right Support Tube (No. 4) with 1 Square Neck Bolt (No. 13), 2 Hexagonal Bolts (No. 14), 1 Hexagonal Bolt (No. 18), 2 Flat Washers (No. 19), 2 Curved Washers (No. 20) and 3 Lock Nuts (No. 21). Secure with the Spanner (No. 10) and the Allen Wrench (No. 11).

NOTE: Do not tighten the 2 Square Neck Bolts (No.13), 4 Hexagonal Bolts (No. 14), 2 Hexagonal Bolts (No. 18) during this step.

We value your experience using Sunny Health and Fitness products. For assistance with parts or troubleshooting, please contact us

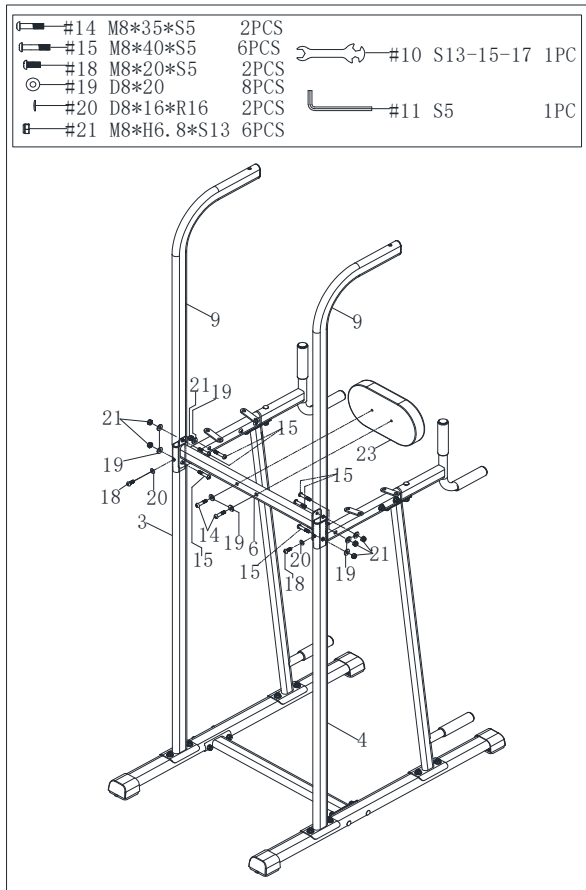

STEP 4:

Attach the **Middle Connecting Tube (No. 6)**, the 2 **Upper Support Tube (No. 9)** onto the **Left & Right Support Tubes (No. 3 & 4)** with 6 **Hexagonal Bolts (No. 15)**, 2 **Hexagonal Bolts (No. 18)**, 6 **Flat Washers (No. 19)**, 2 **Curved Washers (No. 20)** and 6 **Lock Nuts (No. 21)**. Secure with the **Spanner (No. 10)** and the **Allen Wrench (No. 11)**.

Attach the **Back Cushion (No. 23)** onto the **Middle Connecting Tube (No. 6)** with 2 **Hexagonal Bolts (No. 14)** and 2 **Flat Washers (No. 19)**. Secure with the **Allen Wrench (No. 11)**.

NOTE: Do not tighten the 6 **Hexagonal Bolts (No. 15)**, 2 **Hexagonal Bolts (No. 18)** during this step.

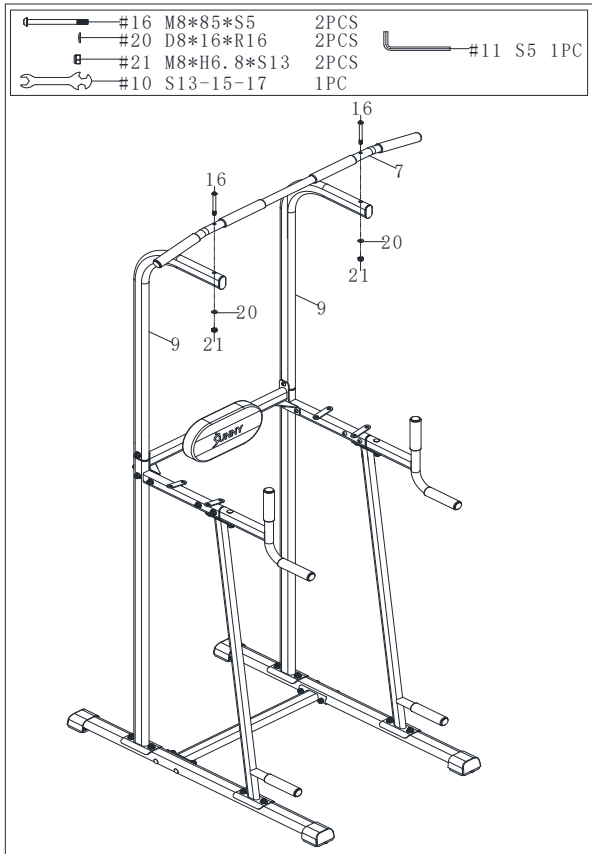

STEP 5:

Attach the **Upper Frame (No. 7)** onto the **Upper Support Tube (No. 9)** with 2 **Hexagonal Bolts (No. 16)**, 2 **Curved Washers (No. 20)** and 2 **Lock Nuts (No. 21)**. Tighten with the **Spanner (No. 10)** and the **Allen Wrench (No. 11)**.

NOTE: Now you can tighten all the Bolts from STEP 1,2,3,4.

We value your experience using Sunny Health and Fitness products. For assistance with parts or troubleshooting, please contact us

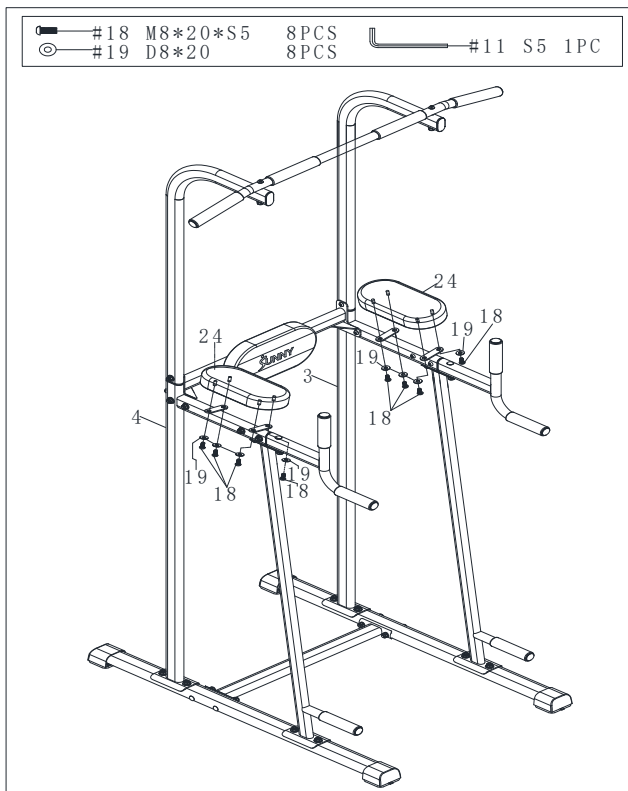

STEP 6:

Attach the 2 **Hand Cushions (No. 24)** onto the **Left & Right Support Tubes (No. 3 & 4)** with 8 **Hexagonal Bolts (No. 18)** and 8 **Flat Washers (No. 19)**. Tighten with the **Allen Wrench (No. 11)**.

The assembly is complete !

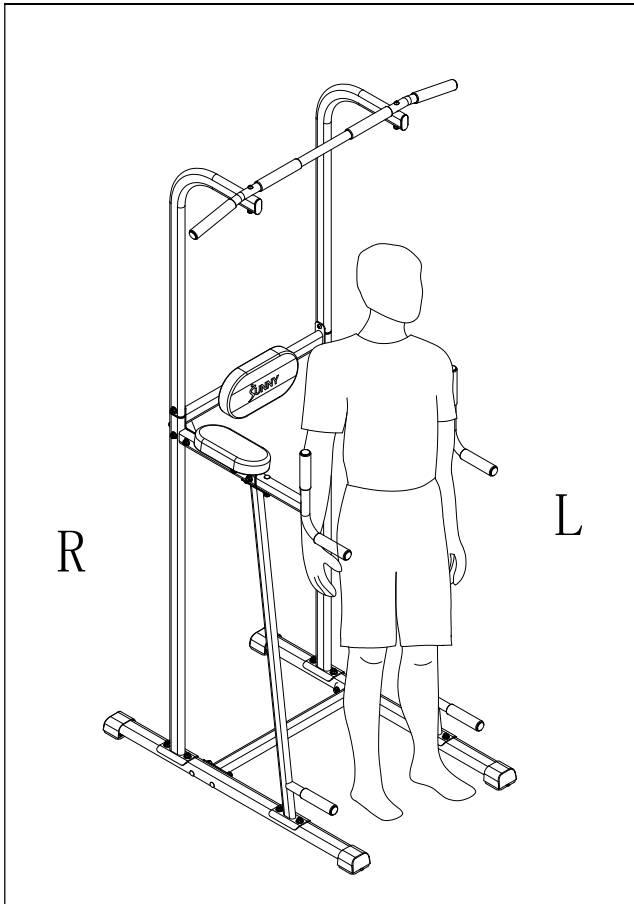

MAINTENANCE INSTRUCTIONS

DAILY MAINTENANCE

Inspect and tighten all parts regularly. (Nuts, Bolts, Rubber Pads, Steel Brackets... etc.)
Replace any worn or torn parts immediately.
Check and ensure the equipment is level at all time.
Check and tighten all adjustment pins/knobs regularly.

WEEKLY MAINTENANCE

Use damp cloth on plastic parts only, use dry cloth on metal frames.
Inspect the metal frame structure of the equipment.

DOWNLOAD SUNNYFIT - FOR HOME FITNESS

SunnyFit is an all-in-one home fitness app designed to empower users of all levels to achieve their fitness goals. Discover over 1,000 free on-demand workout video courses crafted by certified trainers, tailored for various exercise equipment such as indoor bikes, treadmills, rowers, ellipticals, dumbbells, bodyweight, and even resistance band exercises. Whether you have equipment or not, SunnyFit offers the perfect workout for every fitness level and preference. You can enjoy a collection of over 300 free workout courses that require nothing more than your body and the SunnyFit app.

PARTS LIST

No.	Description	Spec.	Qty.	No.	Description	Spec.	Qty.
1	Bottom Connecting Tube		1	15	Hexagonal Bolt	M8*40*S5	6
2	Front Support Tube		2	16	Hexagonal Bolt	M8*85*S5	2
3	Left Support Tube		1	17	Square Neck Bolt	M8*75	4
4	Right Support Tube		1	18	Hexagonal Bolt	M8*20*S5	12
5	Elbow Support Tube		2	19	Flat Washer	D8*20	36
6	Middle Connecting Tube		1	20	Curved Washer	D8*16*R16	12
7	Upper Frame		1	21	Lock Nut	M8*H6.8*S13	26
8L	Left Bottom Tube		1	22	Round Pule	Φ25	8
8R	Right Bottom Tube		1	23	Back Cushion	280*150*40	1
9	Upper Support Tube		2	24	Hand Cushion	250*120*40	2
10	Spanner	S13-S15-S17	1	25	Foot Cover	60*30	4
11	Allen Wrench	S5	1	26	Oval Plug	50*25	2
12	Hexagonal Bolt	M8*45*S5	8	27	Long Foam Grip	Φ22*3*160	8
13	Square Neck Bolt	M8*65	2	28	Short Foam Grip	Φ23*3*120	2
14	Hexagonal Bolt	M8*35*S5	6	29	Oval Plug	60*30	4