



ENERGY FLEX MOTORIZED AUTO INCLINE SMART TREADMILL SF-T7724 SMART USER MANUAL



IMPORTANT! Please retain owner's manual for maintenance and adjustment instructions. Your satisfaction is very important to us, **PLEASE DO NOT RETURN UNTIL YOU HAVE CONTACTED US:** support@sunnyhealthfitness.com or 1-877-90SUNNY (877-907-8669).



WWW.SUNNYHEALTHFITNESS.COM

IMPORTANT SAFETY INFORMATION

We thank you for choosing our product. To ensure your safety and health, please use this equipment correctly. It is important to read this entire manual before assembling and using the equipment. Safe and effective use can only be achieved if the equipment is assembled, maintained, and used properly. It is your responsibility to ensure that all users of the equipment are informed of all warnings and precautions.

1. Before starting any exercise program, you should consult your physician to determine if you have any medical or physical conditions that could put your health and safety at risk or prevent you from using the equipment properly. Your physician's advice is essential if you are taking medication that affects your heart rate, blood pressure, or cholesterol level.
2. Be aware of your body's signals. Incorrect or excessive exercise can damage your health. Stop exercising if you experience any of the following symptoms: pain, tightness in your chest, irregular heartbeat, shortness of breath, lightheadedness, dizziness, or feelings of nausea. If you do experience any of these conditions, you should consult your physician before continuing with your exercise program.
3. Keep children and pets away from the equipment. The equipment is designed for adult use only.
4. Use the equipment on a solid, flat level surface with a protective cover for your floor or carpet. To ensure safety, the equipment should have at least 8 feet (240 cm) of free space behind it and 2 feet (60 cm) on each side. Do not place the treadmill on any surface that blocks air openings. To protect the floor or carpet from damage, place a mat under the treadmill.
5. Ensure that all nuts and bolts are securely tightened before using the equipment. The safety of the equipment can only be maintained if it is regularly examined for damage and/or wear and tear.
6. Always use the equipment as indicated. If you find any defective components while assembling or checking the equipment, or if you hear any unusual noises coming from the equipment during exercise, discontinue use of the equipment immediately and do not use until the problem has been rectified.
7. Wear suitable clothing while using the equipment. Avoid wearing loose clothing that may become entangled in the equipment.
8. Do not place fingers or objects into the moving parts of the equipment.
9. The maximum weight capacity of this unit is 275 lbs (125 kgs).
10. The equipment is not suitable for therapeutic use.
11. To avoid bodily injury and/or damage to the product or property, proper lifting and moving is required.
12. Your product is intended for use in cool, dry conditions. You should avoid storage in extreme cold, hot or damp areas as this may lead to corrosion and other related problems.
13. This equipment is designed for indoor and home use only, it is not intended for commercial use!





IMPORTANT NOTE:

The running belt must be lubricated before the first use! Please see Page 6 for instructions on how to properly apply lubricant.

ASSEMBLY CONTENTS

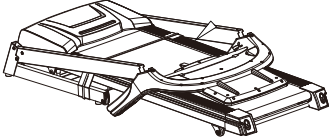
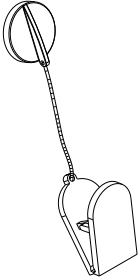
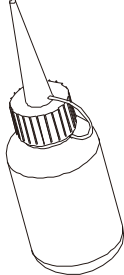
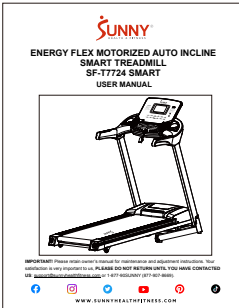
WHEN YOU OPEN THE CARTON, YOU WILL FIND THE FOLLOWING PARTS:

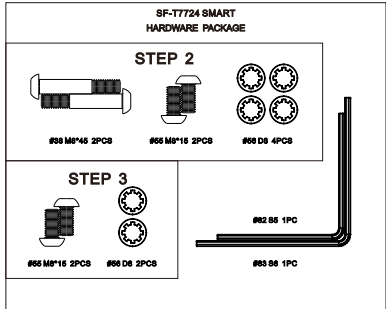
 <p style="text-align: center;">2</p>	 <p style="text-align: center;">76</p>	 <p style="text-align: center;">81</p>
 <p style="text-align: center;">A</p>	 <p style="text-align: center;">B</p>	 <p style="text-align: center;">C</p>

No.	Description	Qty.
2	Main Frame	1
76	Safety Key	1
81	Silicone Oil	1
A	Manual	1
B	Thank You Card	1
C	Hardware Package	1

HARDWARE PACKAGE

SF-T7724 SMART HARDWARE PACKAGE

STEP 2

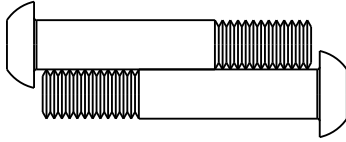

#38 M8*45 L15 2PCS

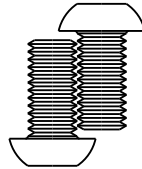

#55 M8*15 2PCS

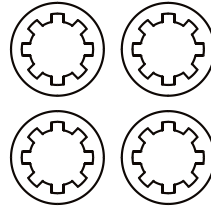

#56 D8 4PCS

STEP 3

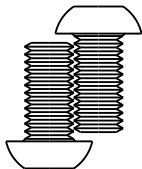

#55 M8*15 2PCS

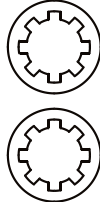

#56 D8 2PCS

#82 S5 1PC

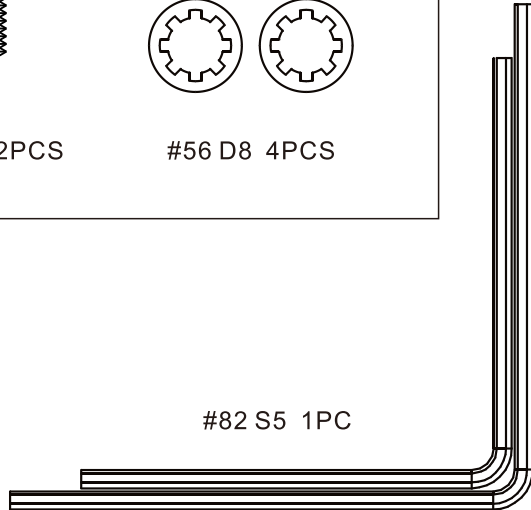

#83 S6 1PC

Ordering Replacement Parts (U.S. and Canadian Customers only)

Please provide the following information in order for us to accurately identify the part(s) needed:

- ✓ The model number (found on cover of manual)
- ✓ The product name (found on cover of manual)
- ✓ The part number found on the "EXPLODED DIAGRAM" (page 20) and "PARTS LIST" (pages 21~22)

Please contact us at support@sunnyhealthfitness.com or 1-877-90SUNNY (877-907-8669).

ASSEMBLY INSTRUCTIONS

We value your experience using Sunny Health and Fitness products. For assistance with parts or troubleshooting, please contact us at support@sunnyhealthfitness.com or 1-877-90SUNNY (877-907-8669).

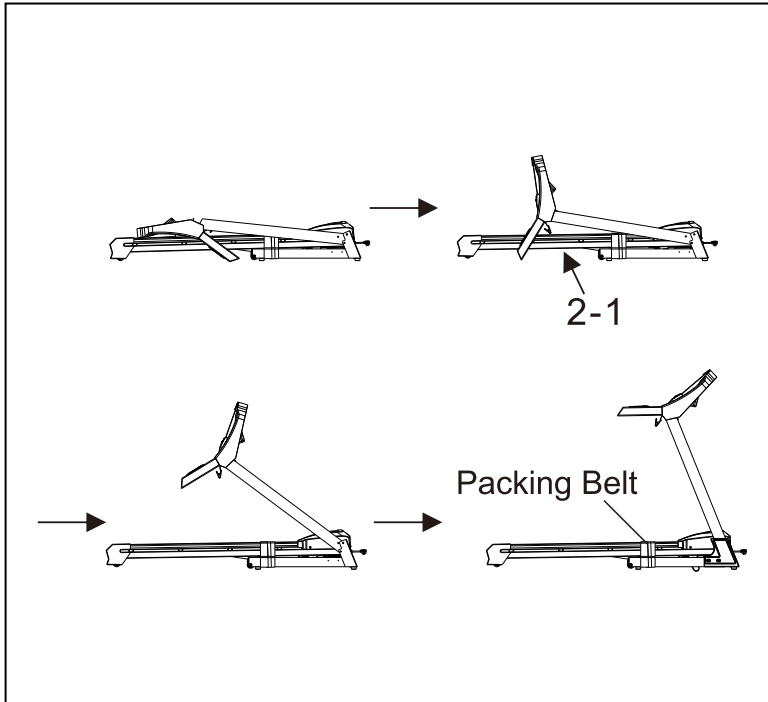

STEP 1:

Open the carton and take out all contents. Place the **Main Frame (No. 2-1)** on level ground and ensure that you have a clean, adequate workspace. Follow the diagram on the left to lift the top console upright.

NOTE: Be careful not to puncture the wires when unfolding! Do not remove the packing belt yet.

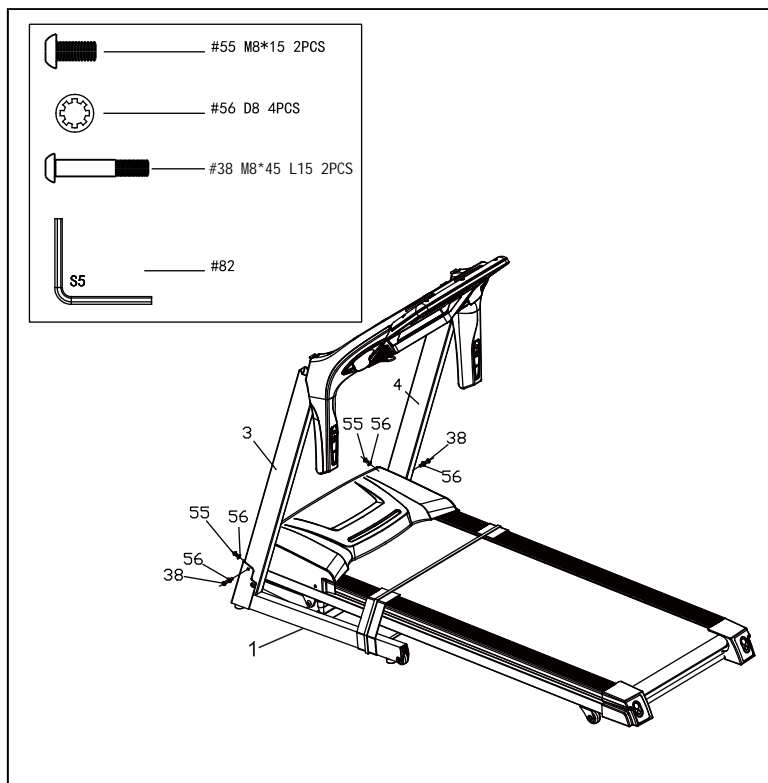

STEP 2:

Secure the **Left & Right Support Tubes (No. 3 & No. 4)** to the **Base Frame (No. 1)** using 2 **Bolts (No. 55)**, 2 **Bolts (No. 38)**, and 4 **Serrated Gaskets (No. 56)**. Tighten and secure with **Allen Wrench (No. 82)**.

We value your experience using Sunny Health and Fitness products. For assistance with parts or troubleshooting, please contact us at support@sunnyhealthfitness.com or 1-877-90SUNNY (877-907-8669).

STEP 3:

Secure the **Top Console (No. 84)** to **Left & Right Support Tubes (No. 3 & No. 4)** using 2 **Bolts (No. 55)** and 2 **Serrated Gaskets (No. 56)**. Tighten and secure with **Allen Wrench (No. 82)**.

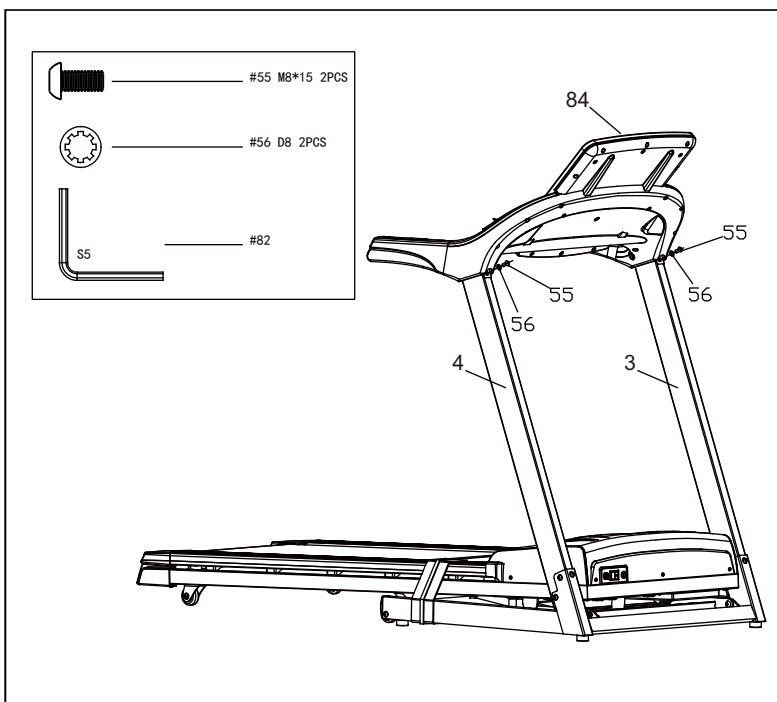

STEP 4:

You may now remove the packing belt. Next, insert the **Safety Key (No. 76)** into the **Top Console (No. 84)**.

NOTE: Attach the clip of the **Safety Key (No. 76)** to your clothing when the treadmill is in use.

NOTE: The running belt must be lubricated before the first use! Please see Page 6 for instructions on how to properly apply lubricant.

The assembly is complete!

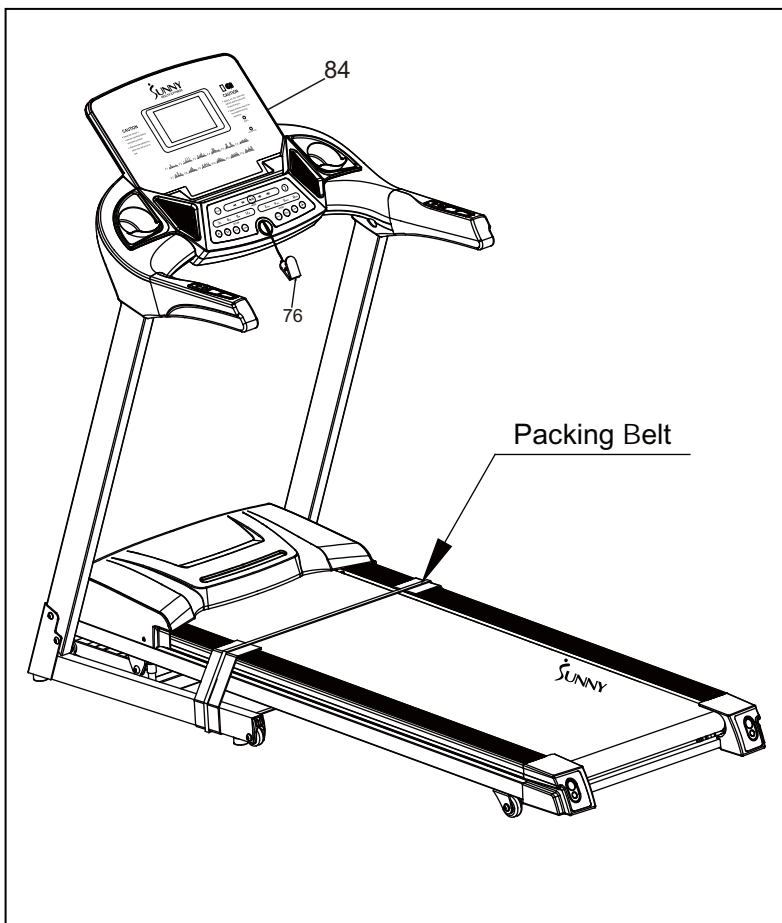

LUBRICATING THE TREADMILL

IMPORTANT NOTE:

You will need to lubricate your treadmill before the first use!

RUNNING BELT & TREADMILL LUBRICANT:

Lubricating the **Running Belt (No. 29)** & **Running Board (No. 28)** is essential as the friction affects the life span and operations of the treadmill. Inspect the **Running Belt (No. 29)** regularly. If you find any wear on the **Running Board (No. 28)**, please contact us at: support@sunnyhealthfitness.com.

WARNING: Always unplug the treadmill from the electrical outlet before cleaning, lubricating, or repairing the unit.

HOW TO LUBRICATE:

Raise the **Running Belt (No. 29)** up on one side and apply lubricant to the **Running Board (No. 28)**. Use a rag to thoroughly wipe the lubricant over the **Running Board (No. 28)**. Repeat this process for the other side.

The following timetable is recommended:

Light user (less than 3 hours/ week)	<i>every 2 months</i>
Medium user (3-5 hours/ week)	<i>every 45 days</i>
Heavy user (more than 5 hours/ week)	<i>every month</i>

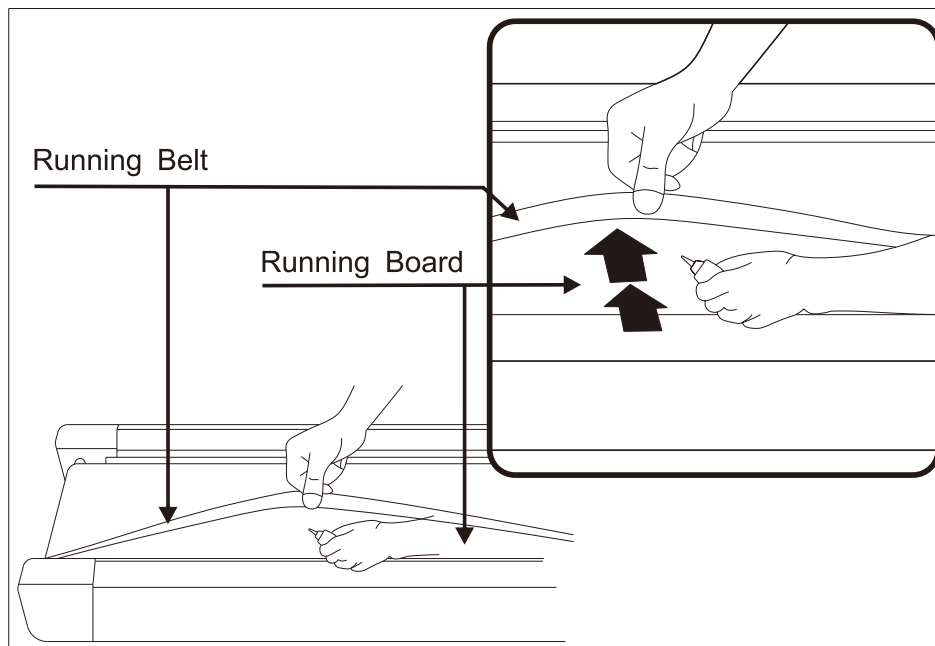

NOTE:

DO NOT LOOSEN OR MAKE ANY ADJUSTMENTS TO THE RUNNING BELT WHILE APPLYING LUBRICANT. A loose **Running Belt (No. 29)** will result in the runner sliding off during use, while too tight of a **Running Belt (No. 29)** will negatively affect the motor's performance and create more friction between the roller and **Running Belt (No. 29)**. The most suitable tightness for the **Running Belt (No. 29)** is when it is pulled out **50-75mm** from the **Running Board (No. 28)**.

MAINTENANCE GUIDE

General cleaning will help to prolong the life and improve performance of your treadmill. Keep the unit clean and maintained by dusting the components on a regular basis. Cleaning two exposed sides of the **Running Belt (No. 29)** to prevent dust from accumulating underneath. Keep your running shoes clean so no dirt will stay on the **Running Board (No. 28)** and **Running Belt (No. 29)**. Clean the surface of the **Running Belt (No. 29)** by using a clean, damp cloth. Keep liquids away from electrical parts and the **Running Belt (No. 29)**.

ADJUSTING THE RUNNING BELT

Place the treadmill on level ground and set it at 3-5 MPH (5-8 KM/H) to check and see if the **Running Belt (No. 29)** drifts from the center. Adjust the **Running Belt (No. 29)** according to below instructions with **Allen Wrench (No. 83)**.

1. If the **Running Belt (No. 29)** drifts to the right, turn the right adjusting bolt $\frac{1}{4}$ turn clockwise, then turn the left adjusting bolt $\frac{1}{4}$ counter-clockwise. If the **Running Belt (No. 29)** does not move, repeat this step until it centers. Refer to image A.

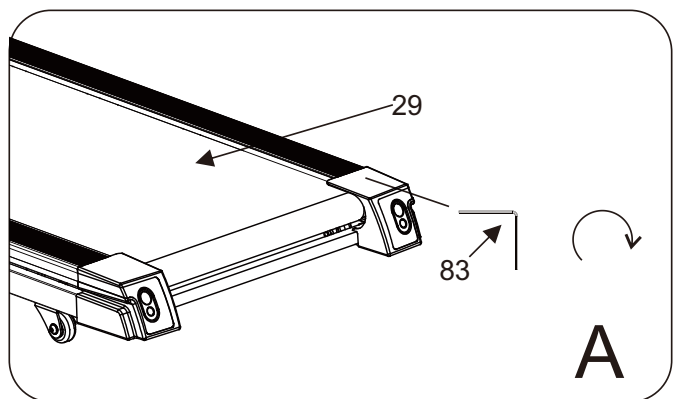

2. If the **Running Belt (No. 29)** drifts to the left, turn the left adjusting bolt $\frac{1}{4}$ turn clockwise, then turn the right adjusting bolt $\frac{1}{4}$ counter-clockwise. If the **Running Belt (No. 29)** does not move, repeat this step until it centers. Refer to image B.

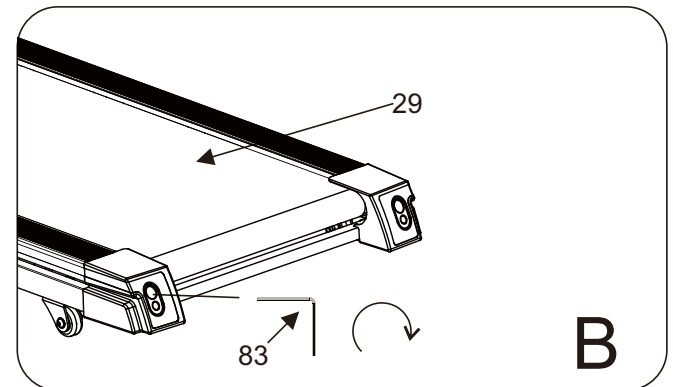

3. Over time, the **Running Belt (No. 29)** will loosen. To tighten the **Running Belt (No. 29)**, turn both the left & right adjusting bolts one full turn clockwise. Check the tension of the **Running Belt (No. 29)**. Continue this process until **Running Belt (No. 29)** is at the correct tension. Make sure to adjust both sides equally to ensure even alignment. Refer to image C.

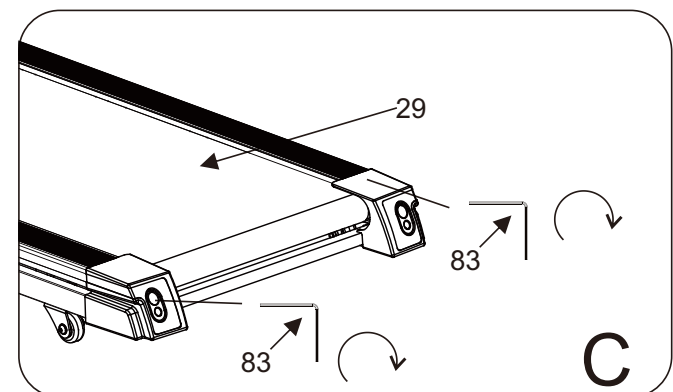

FOLDING INSTRUCTIONS

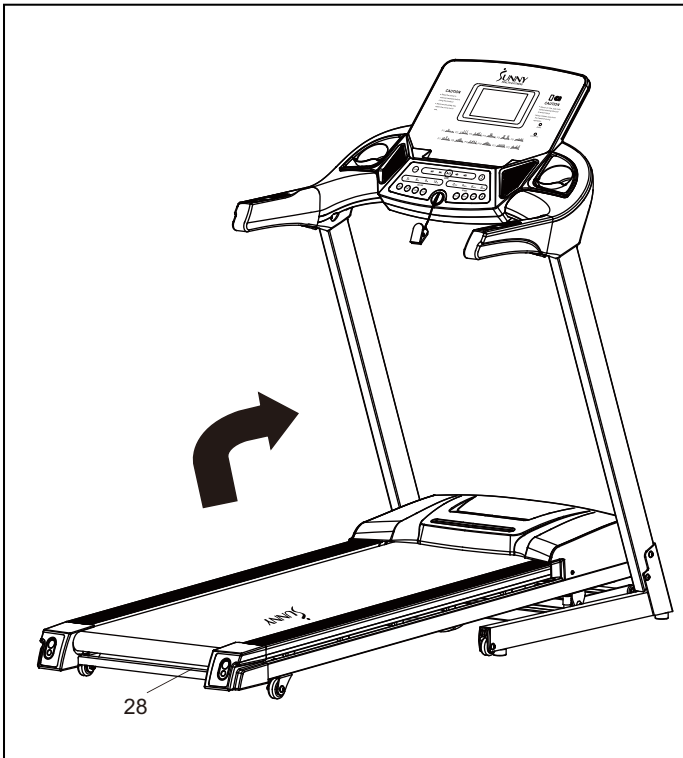

NOTE: Please make sure the incline is at ZERO when folding and unfolding.

FOLDING:

To fold the treadmill, place your hands at the end of the **Running Board (No. 28)** and lift the **Running Board (No. 28)** all the way up until you hear the safety lock “Click” from the **Cylinder (No. 31)**.

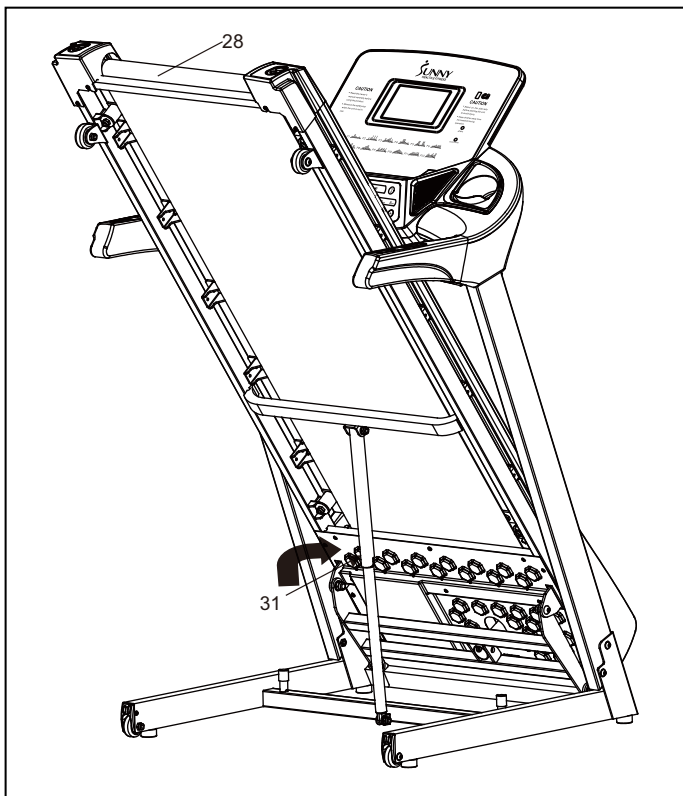



UNFOLDING:

To unfold the treadmill, simply give the **Cylinder (No. 31)** a light kick and pull down the **Running Board (No. 28)** at the same time. With its soft drop system, the treadmill will unfold slowly.

(Please keep everyone and all pets away from the treadmill when unfolding the treadmill).

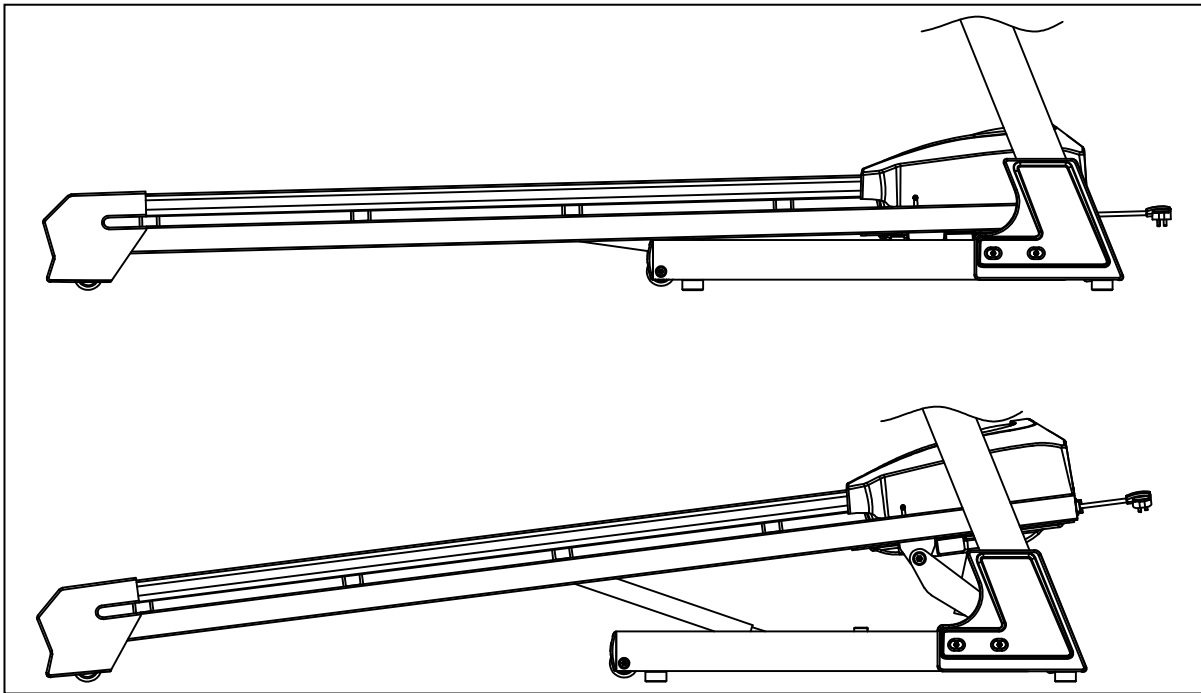
INCLINE INSTRUCTIONS



Console Keys   and **+ - INCLINE Handrail Keys** are used to control the incline level. Increase or decrease the incline level by pressing the incline keys once per level or holding an incline key down to skip through to the desired level.

INCLINE LEVELS

- (0) = 2.23° (3.89%)
- (1) = 2.49° (4.35%)
- (2) = 2.70° (4.71%)
- (3) = 2.93° (5.12%)
- (4) = 3.14° (5.48%)
- (5) = 3.36° (5.87%)
- (6) = 3.62° (6.38%)
- (7) = 3.88° (6.78%)
- (8) = 4.15° (7.25%)
- (9) = 4.45° (7.78%)
- (10) = 4.79° (8.38%)
- (11) = 5.14° (8.99%)
- (12) = 5.51° (9.65%)
- (13) = 5.94° (10.4%)
- (14) = 6.42° (11.25%)
- (15) = 6.80° (11.92%)

Quick 3, 6, 9, 12 INCLINE Keys give you the ability to instantly program a specific incline level with the push of a key.

HOW TO MOVE THE TREADMILL

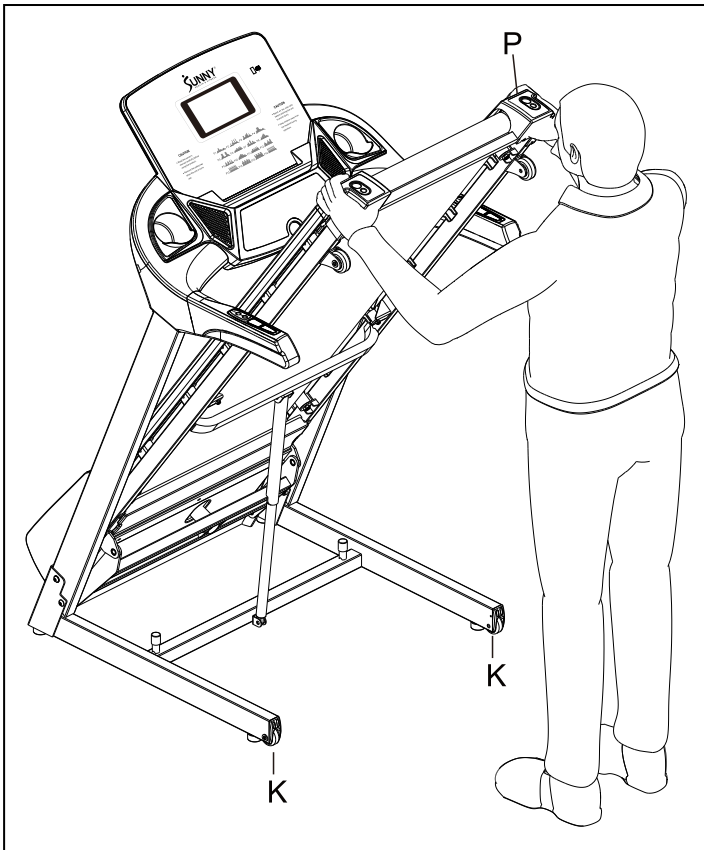

Before attempting to move the treadmill, make sure that it has been properly folded. Then, unplug the power cord.

To tilt, start by placing one hand at position "P" to support the top end of the treadmill. Next, place one foot at position "K" to hold the bottom end of the treadmill steady. With your foot at "K", slowly tilt the top of the treadmill downward towards the ground. Once the main frame "P" reaches a low enough point, the transportation wheels of the treadmill will touch the ground.

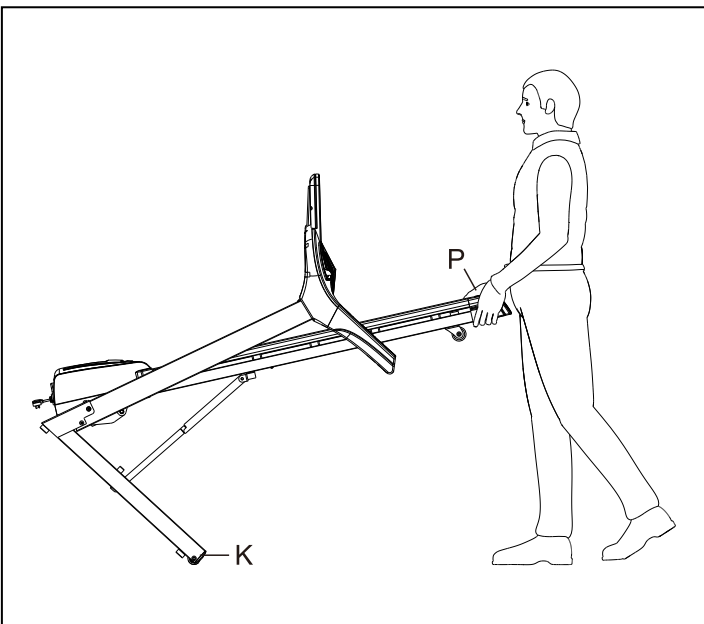

To transport, hold the treadmill from position "P" and tilt until the transportation wheel's "K" are able to move on the ground.

IMPORTANT ELECTRICAL INFORMATION

IMPORTANT NOTE:

This treadmill requires a power source of **120 Volts** in order to properly operate. For your safety, as well as the safety of others, please verify that the power source is correct before powering the equipment. Any power supply source above or below this level could cause significant damage to the equipment and/or user.

GROUNDING METHODS:

This product must be grounded. Should the treadmill malfunction or breakdown, grounding provides a path of least resistance for electric current to reduce the risk of electric shock. This product is equipped with a plug that has an equipment-grounding conductor and a grounding plug. The plug must be plugged into an appropriate outlet that is properly installed and grounded in accordance with all local codes and ordinances.

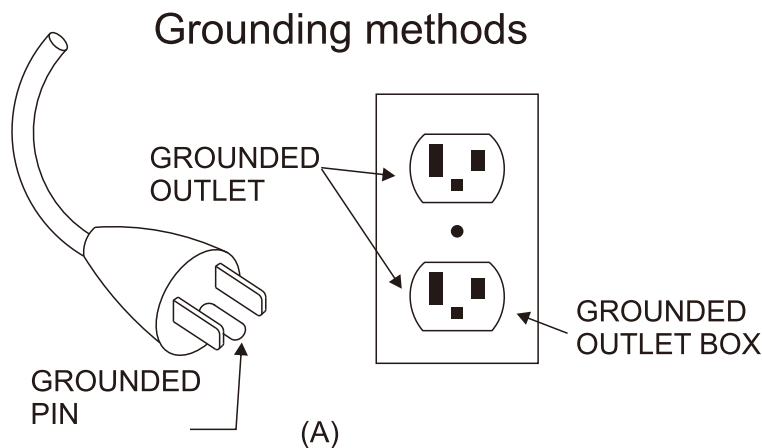

CAUTION:

Improper connection of the equipment can result in risk of electric shock. Check with a qualified electrician or serviceman if you are unsure whether the product has been properly grounded. Do not modify the plug provided with this product. If it will not fit the outlet, have a proper outlet installed by a qualified electrician. Ensure that the product is connected to an outlet with the same configuration as the plug. Do not use an adaptor for this product.

WARNING!

1. **NEVER** use a ground fault circuit interrupt (GFCI) outlet with this treadmill. Route the power cord away from all moving parts of the treadmill, including the Air Pressure Cylinder and transportation wheels.
2. **NEVER** operate the treadmill using a generator or UPS power supply.
3. **NEVER** remove any cover on this treadmill without first disconnecting the power cord.
4. **NEVER** expose the treadmill to rain or moisture. This treadmill is not designed for outdoor use or use in any high humidity environment.

THE DISPLAY CONSOLE

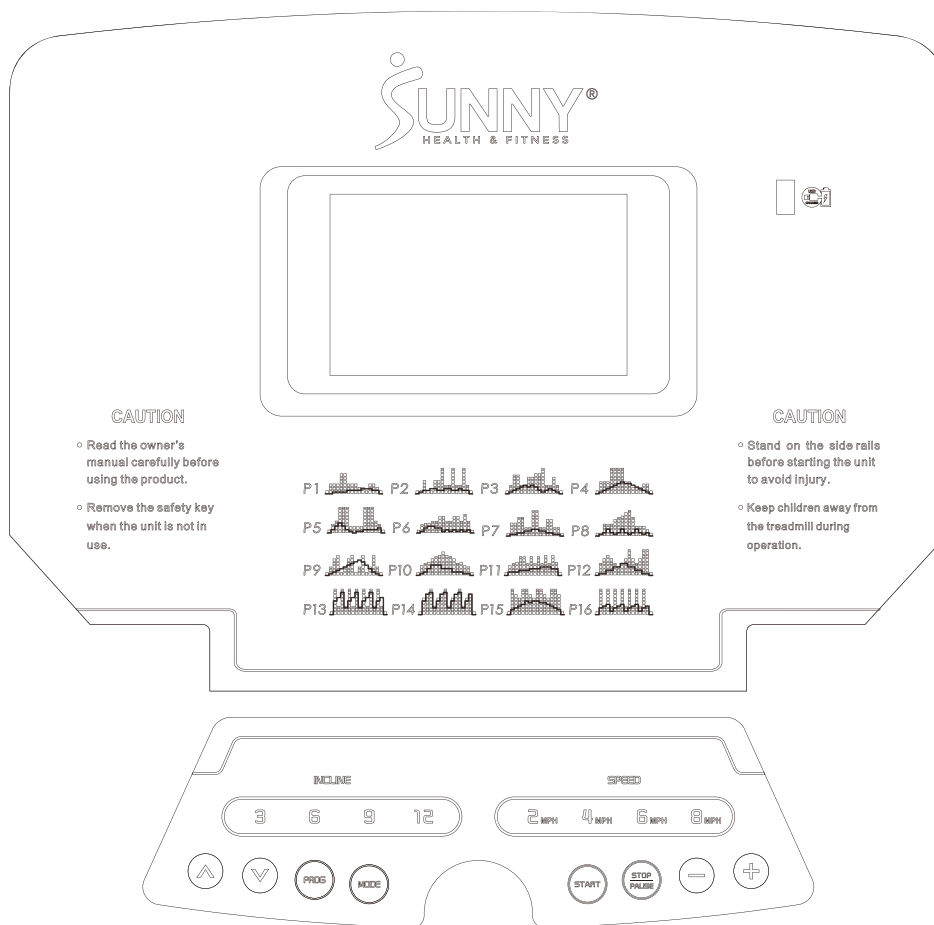

DISPLAY

The treadmill will start after a 3 seconds countdown.

1. **PROGRAM:** In addition to manual mode, there are 16 preset programs (P1-P16) and 3 user programs (U1-U3).
2. **SPEED:** The speed range is 0.6 MPH -10 MPH (1.0-16 KM/H). The initial default speed is 0.6 MPH (1.0 KM/H).
3. **TIME:** Displays the time elapsed (0:00-99:59 MINS). If the time reaches 99:59, the treadmill will stop smoothly and display "End" then automatically reset to 0:00 after 10 seconds. When in Countdown Mode, it will count from the set time to 0:00. When the clock reaches 0:00, the treadmill will stop smoothly and display "End" then automatically reset itself after 10 seconds.
4. **DISTANCE:** Displays the total distance traveled or distance countdown (0.00-99.9 MILES) (0.00 -99.9 KM). Displayed every 5 seconds.
5. **CALORIES:** Displays total calories burned or calories countdown (0.0-999 KCAL). Displayed every 5 seconds.
6. **INCLINE:** Displays the current incline (0-15 INCLINE).
7. **PULSE:** Displays your pulse data when hands are placed on the sensors (50-200 BPM).
8. **SAFETY KEY:** The safety key lock acts as an emergency stop function. In case of emergency, simply remove the **Safety Key (No. 76)** from the console and the console will beep twice and bring the running belt to a complete stop.
9. **STEP:** Displays the total steps (1-99999 steps). Displayed every 5 seconds.

UNIT CONVERSIONS FROM IMPERIAL TO METRIC SYSTEM

First, remove the **Safety Key (No. 76)** from **Top Console (No. 84)** then press “PROG (PROGRAM)” and “MODE” keys together for 5 seconds. The display will show “10.0” or “16.0”. For Imperial System, return the **Safety Key (No. 76)** to **Top Console (No. 84)** when “10.0” is displayed. For Metric system, return the **Safety Key (No. 76)** to **Top Console (No. 84)** when “16.0” is displayed.

NOTE: If treadmill is converted to Metric System, speed and distance will be measured in Kilometers and Kilometers/Hour.

FUNCTION KEYS/MANUAL MODE

1. **START:** Insert the **Safety Key (No. 76)** into the **Top Console (No. 84)** and press “START” key to start the treadmill. The treadmill will initiate at the default running speed of 0.6 MPH (1.0 KM/H).
2. **STOP/PAUSE:** This key has functions of PAUSE and STOP. When in use, press this key once to PAUSE your workout and the current workout data will still be shown. Press “STOP/PAUSE” key again to terminate your workout session completely and all data will be deleted and reset to the initial setting.
3. **SPEED +/- KEYS:** During use, use these keys to increase or decrease your speed. The speed will adjust 0.1 MPH (0.1 KM/H) at a time.
4. **PROG (PROGRAM) KEY:** Press the “PROG (PROGRAM)” key while the treadmill is not running to manually cycle through and choose a program. Programs range from P1-P16, and 3 personalized user programs U1-U3 and FAT calculation.
5. **MODE:** Press this key to choose which **Countdown Mode** to preset before starting the treadmill.
 - a. Press the “MODE” key to set the desired **H-1 (TIME)**, **H-2 (DISTANCE)**, or **H-3 (CALORIES)** setting to countdown from.
 - i. **H-1 (TIME):** Countdown is set at the initial time setting of 30:00 MINS. You may increase or decrease the set time by pressing the SPEED +/- keys. The time setting range is from 5:00-99:00 MINS.
 - ii. **H-2 (DISTANCE):** Countdown is set at the initial distance setting of 1.00 MILE (1.00 KM). You may increase or decrease the set distance by pressing the SPEED +/- keys. The distance setting range is from 1.00-99.0 MILES (1.00-99.0 KM).
 - iii. **H-3 (CALORIES):** Countdown is set at the initial calories setting of 50.0 KCAL. You may increase or decrease the set calories by pressing the SPEED +/- keys. The calories setting range is from 20.0-990 KCAL.
 - b. Press “START” key to begin this exercise.
6. **2MPH, 4MPH, 6MPH, 8MPH (QUICK SPEED KEYS):** Use these quick speed keys to instantly bring the running belt to the desired speed of 2MPH, 4MPH, 6MPH or 8MPH. If the treadmill is converted to Metric System, the quick speed buttons will display 3 KM/H, 6 KM/H, 9 KM/H, 12 KM/H.
7. **3, 6, 9, 12 (QUICK INCLINE KEYS):** Use these quick incline keys to instantly bring the treadmill to an incline of 3, 6, 9, or 12.
8. **USB CHARGER:** Connect the USB input to charge your mobile device.

USER PROGRAMS (U1-U3):

User program is made up of 16 segments. You are allowed to personalize each segment of your exercise by programming each individual segment's time duration, desired speed, and incline.

1. Press the "PROG (PROGRAM)" key to select U1, U2, or U3.
2. Press "MODE" key to enter the setting mode and set the time of the 1st segment.
3. Next, set the desired speed of the 1st segment by pressing the SPEED +/- keys.
4. Set the incline by pressing the INCLINE +/- keys.
5. Press "MODE" key and your 1st segment is set.
6. Repeat the instructions above (3 to 5) until you've completed programming all 16 segments.
7. Press "START" key to save and start your exercise.

BODY FAT CALCULATION:

1. Press the "PROG (PROGRAM)" key until the window displays **FAT**.
2. Press "MODE" key to enter below by pressing the SPEED +/- keys to set the data accordingly:
 - a. F1 – Gender
 - b. F2 – Age
 - c. F3 – Height
 - d. F4 – Weight
3. Hold the hand pulse sensors, it will start calculating and provide you with your BODY FAT.

NOTE: Average Body Fat score is 20-25

F1	Sex	01 MALE	02 FEMALE
F2	Age	10 to 99 years old	
F3	Height	40----80 inches (100-220 cm)	
F4	Weight	44----330 lbs (20-150 kgs)	
F5	Body Fat	≤19	Underweight
	Body Fat	=(20---25)	Average Weight
	Body Fat	=(26---29)	Overweight
	Body Fat	≥30	Obesity

PROGRAMS

Each program is divided into 16 exercise segments in an equal time division. Please use below chart for Imperial or Metric system.

Program in Imperial System (Miles/Hour)

TIME MODE		SET TIME/16															
		1	2	3	4	5	6	7	8	9	10	11	12	13	14	15	16
P1	SPEED	1.2	3.1	3.1	3.1	6.2	6.2	3.1	3.1	3.1	1.9	1.9	1.2	3.1	3.1	1.9	1.2
	INCLINE	0	0	1	1	1	1	2	2	2	2	3	3	3	2	2	0
P2	SPEED	1.2	1.2	4.3	1.2	1.2	4.3	4.3	7.5	2.5	2.5	7.5	2.5	2.5	7.5	2.5	1.2
	INCLINE	0	1	2	2	3	3	2	2	3	3	2	2	3	2	2	0
P3	SPEED	1.2	2.5	5.6	5.6	2.5	2.5	5	5	6.2	6.2	7.5	2.5	2.5	5	2.5	1.2
	INCLINE	0	1	2	3	4	5	4	5	4	2	1	2	3	2	1	0
P4	SPEED	1.2	3.7	3.7	3.7	7.5	7.5	7.5	7.5	3.7	3.7	1.9	1.9	1.9	3.1	3.1	1.2
	INCLINE	0	1	2	3	4	5	6	7	6	6	5	4	3	2	1	0
P5	SPEED	1.2	2.5	3.7	7.5	7.5	7.5	1.9	1.9	1.9	1.9	7.5	7.5	7.5	3.7	2.5	1.2
	INCLINE	0	2	4	6	4	2	1	0	1	1	2	2	2	2	3	0
P6	SPEED	1.2	2.5	3.1	3.1	3.7	3.7	5	5	3.7	3.7	5	5	3.7	5.6	3.7	1.2
	INCLINE	0	1	3	4	4	3	3	1	2	1	2	1	2	1	2	0
P7	SPEED	1.2	4.3	4.3	5.6	5.6	2.5	2.5	7.5	7.5	2.5	2.5	5	5	2.5	2.5	1.2
	INCLINE	0	1	1	2	2	3	3	4	4	3	3	2	2	1	1	0
P8	SPEED	1.2	1.2	3.7	3.7	3.7	5	5.6	6.2	6.8	7.5	5.6	3.1	3.1	3.1	1.9	1.2
	INCLINE	0	1	2	4	2	1	2	4	2	1	2	4	2	1	2	0
P9	SPEED	1.2	2.5	5	6.2	1.2	2.5	5	6.2	1.2	2.5	6.2	1.2	2.5	6.2	2.5	1.2
	INCLINE	0	1	2	3	4	5	6	7	8	9	8	6	4	2	1	0
P10	SPEED	1.2	3.1	3.7	4.3	5	5.6	6.2	6.8	6.2	5.6	5	3.7	4.3	3.1	2.5	1.2
	INCLINE	0	1	2	4	6	6	6	4	4	4	2	2	2	1	1	0
P11	SPEED	1.2	3.1	3.7	4.3	5.6	5.6	3.7	5.6	3.7	5.6	3.7	6.2	3.7	6.2	4.3	1.2
	INCLINE	0	2	2	2	3	3	3	4	4	4	5	5	5	4	4	0
P12	SPEED	1.2	3.7	5	6.2	5	3.7	2.5	3.7	5	7.5	5	3.7	5	7.5	7.5	1.2
	INCLINE	0	1	1	3	3	5	5	7	7	5	5	3	3	1	1	0
P13	SPEED	1.2	7.5	2.5	7.5	2.5	7.5	2.5	7.5	2.5	7.5	2.5	7.5	2.5	7.5	2.5	1.2
	INCLINE	0	8	10	13	4	8	10	13	4	8	10	13	4	8	10	0
P14	SPEED	1.2	5	6.2	7.5	2.5	5	6.2	7.5	2.5	5	6.2	7.5	2.5	5	6.2	1.2
	INCLINE	0	8	12	13	4	8	12	13	4	8	12	13	4	8	12	0
P15	SPEED	1.2	7.5	6.2	5	7.5	7.5	6.2	5	7.5	7.5	6.2	5	7.5	7.5	6.2	1.2
	INCLINE	0	3	4	5	6	8	7	8	8	7	7	6	5	4	3	0
P16	SPEED	1.2	7.5	2.5	7.5	2.5	7.5	2.5	7.5	2.5	7.5	2.5	7.5	2.5	7.5	2.5	1.2
	INCLINE	0	4	5	6	2	4	5	6	2	4	5	6	2	4	5	0

Program in Metric System (Kilometers/Hour)

TIME		SET TIME/16															
		1	2	3	4	5	6	7	8	9	10	11	12	13	14	15	16
P1	SPEED	2	5	5	5	10	10	5	5	5	3	3	2	5	5	3	2
	INCLINE	0	0	1	1	1	1	2	2	2	2	3	3	3	2	2	0
P2	SPEED	2	2	7	2	2	7	7	12	4	4	12	4	4	12	4	2
	INCLINE	0	1	2	2	3	3	2	2	3	3	2	2	3	2	2	0
P3	SPEED	2	4	9	9	4	4	8	8	10	10	12	4	4	8	4	2
	INCLINE	0	1	2	3	4	5	4	5	4	2	1	2	3	2	1	0
P4	SPEED	2	6	6	6	12	12	12	12	6	6	3	3	3	5	5	2
	INCLINE	0	1	2	3	4	5	6	7	6	6	5	4	3	2	1	0
P5	SPEED	2	4	6	12	12	12	3	3	3	3	12	12	12	6	4	2
	INCLINE	0	2	4	6	4	2	1	0	1	1	2	2	2	2	3	0
P6	SPEED	2	4	5	5	6	6	8	8	6	6	8	8	6	9	6	2
	INCLINE	0	1	3	4	4	3	3	1	2	1	2	1	2	1	2	0
P7	SPEED	2	7	7	9	9	4	4	12	12	4	4	8	8	4	4	2
	INCLINE	0	1	1	2	2	3	3	4	4	3	3	2	2	1	1	0
P8	SPEED	2	2	6	6	6	8	9	10	11	12	9	5	5	5	3	2
	INCLINE	0	1	2	4	2	1	2	4	2	1	2	4	2	1	2	0
P9	SPEED	2	4	8	10	2	4	8	10	2	4	10	2	4	10	4	2
	INCLINE	0	1	2	3	4	5	6	7	8	9	8	6	4	2	1	0
P10	SPEED	2	5	6	7	8	9	10	11	10	9	8	6	7	5	4	2
	INCLINE	0	1	2	4	6	6	6	4	4	4	2	2	2	1	1	0
P11	SPEED	2	5	6	7	9	9	6	9	6	9	6	10	6	10	7	2
	INCLINE	0	2	2	2	3	3	3	4	4	4	5	5	5	4	4	0
P12	SPEED	2	6	8	10	8	6	4	6	8	12	8	6	8	12	12	2
	INCLINE	0	1	1	3	3	5	5	7	7	5	5	3	3	1	1	0
P13	SPEED	2	12	4	12	4	12	4	12	4	12	4	12	4	12	4	2
	INCLINE	0	8	10	13	4	8	10	13	4	8	10	13	4	8	10	0
P14	SPEED	2	8	10	12	4	8	10	12	4	8	10	12	4	8	10	2
	INCLINE	0	8	12	13	4	8	12	13	4	8	12	13	4	8	12	0
P15	SPEED	2	12	10	8	12	12	10	8	12	12	10	8	12	12	10	2
	INCLINE	0	3	4	5	6	8	7	8	8	7	7	6	5	4	3	0
P16	SPEED	2	12	4	12	4	12	4	12	4	12	4	12	4	12	4	2
	INCLINE	0	4	5	6	2	4	5	6	2	4	5	6	2	4	5	0

APP CONNECTION

CONNECT SMART EQUIPMENT TO SUNNYFIT APP:

1. Scan to download SunnyFit from the app store.



2. Ensure that the Bluetooth function is turned on from your mobile device.
3. If this is your first time using the SunnyFit app, follow the in-app instructions to register for your free SunnyFit account and log in.
4. Begin any workout activity that matches your smart equipment, then follow the onscreen prompts to search for and connect to your smart equipment.
5. When connected, your stats and records will be displayed at the end of your course/session, and recorded in your account profile!

TROUBLESHOOTING:

1. If you are having trouble connecting your smart equipment, visit www.sunnyfit.com/guide or scan the QR code below:



2. If you require additional support, please contact support@sunnyfit.com.

TECHNICAL DATA

Connectivity: Bluetooth LE

Frequency Range: 2400~2483.5 Mhz

Transmitting Power: 0 dBm

EXERCISE INSTRUCTIONS

GETTING STARTED:

Before starting any exercise programs, you should consult your physician to determine if you have any medical or physical conditions that could put your health and safety at risk or prevent you from using the treadmill properly. Be aware of your body's signals. Incorrect or excessive exercise can damage your health. Stop exercising immediately if you experience any of the following symptoms: pain, tightness in your chest, irregular heartbeat, extreme shortness of breath, lightheadedness, dizziness, or feelings of nausea.

Turn on the power switch located next to the power cord. Get to know your treadmill. Before attempting to use the treadmill, take some time to stand alongside it and familiarize yourself with the controls. Once you feel comfortable to get on, you can stand with your feet on the foot rails and balance yourself by putting your hands on the handrails.

Next, attach the clip end of the **Safety Key (No. 76)** to your clothing and insert the magnetic end of the key into the console. Press the "START" key to start the treadmill. The treadmill will start at the default speed of 0.6 MPH (1.0 KM/H). Once you feel comfortable, you may slowly increase the speed. When you are finished with your exercise, press the "STOP/PAUSE" key or remove the magnetic end of **Safety Key (No. 76)** to stop the treadmill.

SAFETY LOCK:

Remove the **Safety Key (No. 76)** from the console to stop the treadmill immediately. Once the treadmill reaches a full stop, the window display on the console will show "---" and the treadmill will beep. To start the treadmill again, insert the magnetic end of **Safety Key (No. 76)** into the console and press "START" key.

POWER SAVE FUNCTION:

Once the treadmill has been inactive for 10 minutes, it will adjust to *Power Saving Mode*. When the treadmill is in *Power Saving Mode*, the window display on the console will shut off. To reactivate, press any key.

POWER OFF:

Power to the treadmill can be turned off at any time without risk during or after an exercise.

CAUTION!

1. We recommend that you maintain a slow speed at the beginning of a session and hold the handrails until you become comfortable and familiar with the treadmill.
2. Insert the magnetic end of the **Safety Key (No. 76)** into the console and attach the opposite end with the safety clip to your clothing before beginning your workout. To end your workout, press the "STOP/PAUSE" key or remove the **Safety Key (No. 76)**. The treadmill will stop immediately.

TROUBLESHOOTING

Code	Description	How to Troubleshoot
-----	Safety key fault.	<ol style="list-style-type: none"> 1. Insert the safety key properly. 2. Replace the safety key sensor or safety key. If there is still a problem, replace the console.
E01	Communication abnormality: no communication from the console to the control board.	<p>Possible Reasons: Communication obstructed between control board and console, please check to make sure the wires are connected properly, and the wires are without any punctures or damage. If this does not resolve the issue, check the control board and PCB IC to see if there's any damage. Replace if necessary.</p>
E02	Motor fault or control board fault.	<ol style="list-style-type: none"> 1. Check if the motor wire is well connected. Reconnect the wire and restart. 2. Check the motor or the control board for any damage. Replace if necessary.
E04	Incline failure: the incline wire is damaged or the wire for the incline motor is not properly connected.	Check incline motor sensor wire and AC wire to see if they are properly connected. Make sure the incline motor wire does not have any punctures or damage.
E05	Current overload protection.	<p>Possible Reasons: Excessive current load, the incoming voltage is too low or too high. The control board is damaged. A moving part of the treadmill is stuck, and the motor is unable to function properly. Press the Overload Protector (No. 63) to restart the treadmill. Also, check if there's any burnt odors around the motor and control board. Make sure the power and voltage comply with the standard. Inspect moving parts to ensure they are operating correctly. Listen for unfamiliar noises from the motor.</p>
E06	Burst clash protection.	<p>Possible Reasons: The power voltage is less than normal by 50% or the controller has problems. Make sure the motor wires are connected. Check the control board for any damage or burnt odors. Replace if necessary.</p>
No display in console	Control board abnormality.	<ol style="list-style-type: none"> 1. Check if the overload button switch is off, if so, press it to turn it on. 2. Check the wire on the power switch, overload protector, and control board to see if it is connected properly. 3. Check the console wires and all cables between the console and control board. 4. Check the transformer and replace if necessary.

EXPLODED DIAGRAM

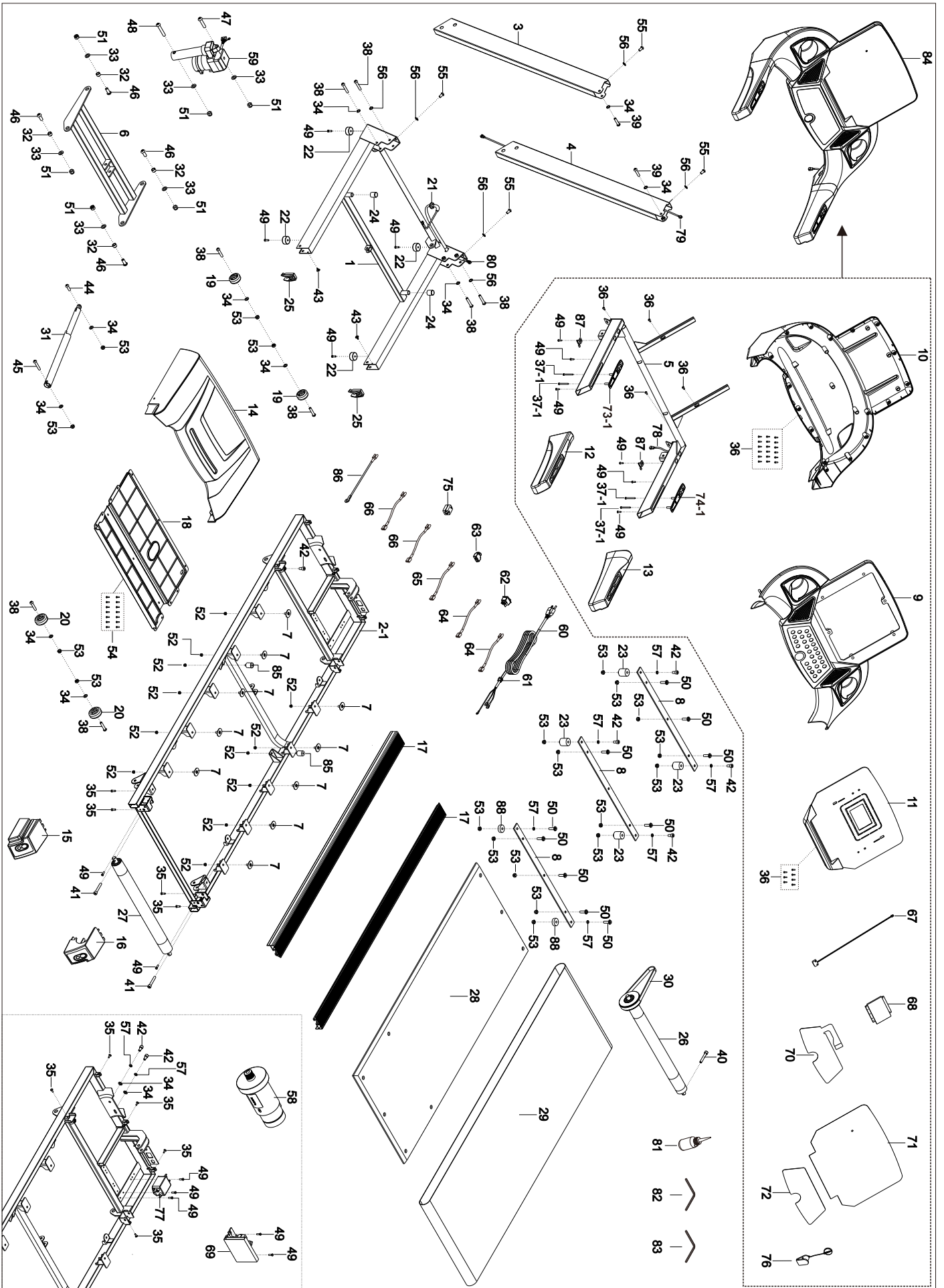

PARTS LIST

No.	Description	Spec.	Qty.
1	Base Frame		1
2-1	Main Frame		1
3	Left Support Tube		1
4	Right Support Tube		1
5	Computer Bracket		1
6	Incline Bracket		1
7	Side Rail Support		10
8	Retainer Plate		3
9	Computer Upper Cover	755*537*115	1
10	Computer Bottom Cover	755*559*138	1
11	Computer Panel	429*337*20	1
12	Left Handrail Bushing	323*97*54	1
13	Right Handrail Bushing	323*97*54	1
14	Motor Cover	607*396*123	1
15	End Cap (L)	133*96*91	1
16	End Cap (R)	133*96*91	1
17	Side Rail	1215*70*17	2
18	Motor Bottom Cover	605*345*22	1
19	Transportation Wheel	Ø45*Ø8.2*20	2
20	Moving Wheel	Ø51.5*Ø8.2*22	2
21	Cable Protector	Ø24*Ø18*9	1
22	Flat Foot Pad	Ø31*Ø6*16	4
23	Cushion	Ø30*32*M8	4
24	Round Cushion	Ø20*Ø16*17.5	2
25	Transportation Wheel Cover	60*30*18.8	2
26	Front Roller	46*558	1
27	Rear Roller	46*550	1
28	Running Board	1210*480*18	1
29	Running Belt	2785*460*1.6	1
30	Motor Belt	210-J6	1
31	Cylinder	610*260-35 kgs	1
32	Incline Bushing	Ø15*Ø10*9	4
33	Flat Washer	Ø20*Ø 10.5*2	6
34	Flat Washer	Ø16*Ø 8.5*1.2	12
35	Screw	ST4.2*13	9
36	Screw	ST4.2*16	29
37-1	Screw	ST4*35	4
38	Bolt	M8*45 L15	8

No.	Description	Spec.	Qty.
39	Bolt	M8*35	2
40	Bolt	M8*50	1
41	Bolt	M8*55	2
42	Roundhead Hex Bolt	M8*15	7
43	Screw	ST4.2*8	2
44	Bolt	M8*25	1
45	Bolt	M8*45 L10	1
46	Bolt	M10*25	4
47	Bolt	M10*45	1
48	Bolt	M10*60	1
49	Screw	M5*15	17
50	Screw	M8*30	10
51	Lock Nut	M10	6
52	Lock Nut	M6	12
53	Lock Nut	M8	20
54	Screw	ST4.2*19	14
55	Half-roundhead Hex Bolt	M8*15	4
56	Serrated Gasket	D8	6
57	Spring Washer	M8	8
58	DC Motor		1
59	Incline Motor		1
60	Power Line	2100mm	1
61	Power Line Plug	6N-3	1
62	Power Switch	250V/16A	1
63	Overload Protector	250V/16A	1
64	Single Blue Wire	250mm	2
65	Single Blue Wire	100mm	1
66	Single Brown Wire	250mm	2
67	Safety Key Sensor		1
68	Computer Chip		1
69	Controller		1
70	Metal Dome Array		1
71	Overlay		1
72	Key Panel Sticker		1
73-1	Incline Hand Pulse		1
74-1	Speed Hand Pulse		1
75	Magnetic Ring		1
76	Safety Key		1

No.	Description	Spec.	Qty.
77	Filter	10A	1
78	Upper Computer Wire		1
79	Middle Computer Wire		1
80	Lower Computer Wire		1
81	Silicone Oil		1
82	Allen Wrench	S5	1

No.	Description	Spec.	Qty.
83	Allen Wrench	S6	1
84	Top Console	1451G	1
85	Cushion	Ø20*20*M6	2
86	Grounded Line		1
87	Computer Cover Support		2
88	Round Cushion	Ø30*Ø8.2*10	2

CONNECT
with us

DOWNLOAD

Track your fitness progress & join
FREE workout courses!

Download  **SUNNYFIT** today!



FOLLOW

Find us on social media @sunnyhealthfitness

 @sunnyhealthfitness

 @sunnyhealthandfitness

 @sunnyhealthfit

 /sunnyhealthfitness

 /sunnyhealthfitness

 /sunnyhealthandfitness

www.sunnyhealthfitness.com