



# SMART TREADMILL WITH AUTO INCLINE

## SF-T7705 SMART

### USER MANUAL



**IMPORTANT!** Please retain owner's manual for maintenance and adjustment instructions. Your satisfaction is very important to us, **PLEASE DO NOT RETURN UNTIL YOU HAVE CONTACTED US:** [support@sunnyhealthfitness.com](mailto:support@sunnyhealthfitness.com) or 1-877-90SUNNY (877-907-8669).



[WWW.SUNNYHEALTHFITNESS.COM](http://WWW.SUNNYHEALTHFITNESS.COM)

# **IMPORTANT SAFETY INSTRUCTION**

When using an electrical appliance, basic precautions should always be followed, including the following:

Read all instructions before using this treadmill.

**DANGER**– To reduce the risk of electrical shock:

1. Always unplug this appliance from the electrical outlet immediately after using and before cleaning.

**WARNING** – To reduce the risk of burns, fire, electric shock, or injury to persons:

1. The treadmill should never be left unattended when plugged in. Unplug from outlet when not in use and before putting on or taking off parts.
2. Use this treadmill only for its intended use as described in this manual. Do not use attachments not recommended by the manufacturer.
3. Never operate this treadmill if it has a damaged cord or plug, if it is not working properly, if it has been dropped or damaged, or dropped into water. Return this treadmill to a service center for examination and repair.
4. Keep the cord away from heated surfaces.
5. Never operate the treadmill with the air openings blocked. Keep the air openings free of lint, hair, and alike items.
6. Never drop or insert any object into any opening.
7. Do not use outdoors.
8. Do not operate where aerosol (spray) products are being used or where oxygen is being administered.
9. To disconnect, turn the treadmill off, then remove the plug from the outlet.
10. Connect this treadmill to a properly grounded outlet only. See grounding instructions.
11. This appliance is not intended for use by persons with reduced physical, sensory, or mental capabilities, or lack of experience and knowledge, unless they have been given supervision or instruction concerning use of the appliance by a person responsible for their safety. Keep children under the age of 13 away from this machine.
12. Household use only.
13. REMOVE CONTROL BOX (OR KEY, OR SAFETY PIN, AS APPLICABLE) WHEN NOT IN USE, AND STORE OUT OF REACH OF CHILDREN.
14. Do not carry this appliance by supply cord or use cord as a handle.

**CAUTION:**

To avoid Injury, use extreme caution when stepping onto or off the running belt. Read instruction manual before using.

**IC CAUTION:** This device contains license-exempt transmitter(s)/receiver(s) that comply with Innovation, Science and Economic Development Canada's license-exempt RSS(s). Operation is subject to the following two conditions:

- (1) This device may not cause interference.
- (2) This device must accept any interference, including interference that may cause undesired operation of the device.

**IC Radiation Exposure Statement:**

This equipment complies with Canada radiation exposure limits set forth for an uncontrolled environment. This equipment should be installed and operated with a minimum distance of 20cm between the radiator and your body.

This transmitter must not be co-located or operating in conjunction with any other antenna or transmitter.

*SAVE THESE INSTRUCTIONS*

# **IMPORTANT SAFETY INFORMATION**

We thank you for choosing our product. To ensure your safety and health, please use this treadmill correctly. It is important to read this entire manual before assembling and using the treadmill. Safe and effective use can only be achieved if the treadmill is assembled, maintained, and used properly. It is your responsibility to ensure that all users of the treadmill are informed of all warnings and precautions.

1. Before starting any exercise program, you should consult your physician to determine if you have any medical or physical conditions that could put your health and safety at risk or prevent you from using the treadmill properly. Your physician's advice is essential if you are taking medication that affects your heart rate, blood pressure, or cholesterol level.
2. Be aware of your body's signals. Incorrect or excessive exercise can damage your health. Stop exercising if you experience any of the following symptoms: pain, tightness in your chest, irregular heartbeat, shortness of breath, lightheadedness, dizziness, or feelings of nausea. If you do experience any of these conditions, you should consult your physician before continuing with your exercise program.
3. Keep children and pets away from the treadmill. The treadmill is designed for adult use only.
4. Use the treadmill on a solid, flat level surface with a protective cover for your floor or carpet. To ensure safety, the treadmill should have at least 8 feet (240cm) of free space behind it and 2 feet (60cm) on each side. Do not place the treadmill on any surface that blocks air openings. To protect the floor or carpet from damage, place a mat under the treadmill.
5. Ensure that all nuts and bolts are securely tightened before using the treadmill. The safety of the treadmill can only be maintained if it is regularly examined for damage and/or wear and tear.
6. Always use the treadmill as indicated. If you find any defective components while assembling or checking the treadmill, or if you hear any unusual noises coming from the treadmill during exercise, discontinue use of the treadmill immediately and do not use until the problem has been rectified.
7. Wear suitable clothing while using the treadmill. Avoid wearing loose clothing that may become entangled in the treadmill.
8. Do not place fingers or objects into the moving parts of the treadmill.
9. The maximum weight capacity of this unit is 220 lbs (100 kgs).
10. The treadmill is not suitable for therapeutic use.
11. To avoid bodily injury and/or damage to the product or property, proper lifting and moving are required.
12. Your product is intended for use in cool and dry conditions. You should avoid storage in extreme cold, hot or damp areas as this may lead to corrosion and other related problems.
13. This treadmill is designed for indoor and home use only; it is not intended for commercial use!

## **IMPORTANT OPERATING INSTRUCTION**

1. Insert the power plug directly into the socket.
2. Read the manual before operating the treadmill.
3. Changes in speed do not occur immediately. Set your desired speed using the adjustment keys on the main console. The speed will increase gradually.
4. While on the treadmill, move with caution as distractions may cause you to lose balance and stray from walking in the center of the running belt. This may result in serious injury.
5. This unit starts at a very low speed. To begin use, hold onto the handrails, and stand on the side rails while it starts up, then step onto the running belt once it is in motion.
6. Always hold the handrail when making changes in the settings.
7. A safety key is provided for emergency use. The treadmill will function only if the safety key is inserted into the console. In case of emergency, remove the safety key to immediately stop the running belt and shut off the treadmill. The display screen will reset once the safety key is reinserted.
8. The console control keys are precisely set and require very little finger pressure to use. To avoid damaging these keys, do not use excessive pressure when operating these controls.
9. This treadmill is designed for adult use only! Children should not be allowed to use or play near this treadmill. When present, children should always be supervised by an adult.
10. Women who are pregnant or nursing should consult a physician before attempting to begin any exercise program.
11. Always stay hydrated during and after exercise.



### **IMPORTANT NOTE:**

The running belt must be lubricated before the first use! Please see *Page 10* for instructions on how to properly apply lubricant.

# PRE-ASSEMBLY CHECK LIST

Before you start to assemble, please make sure all parts are included.

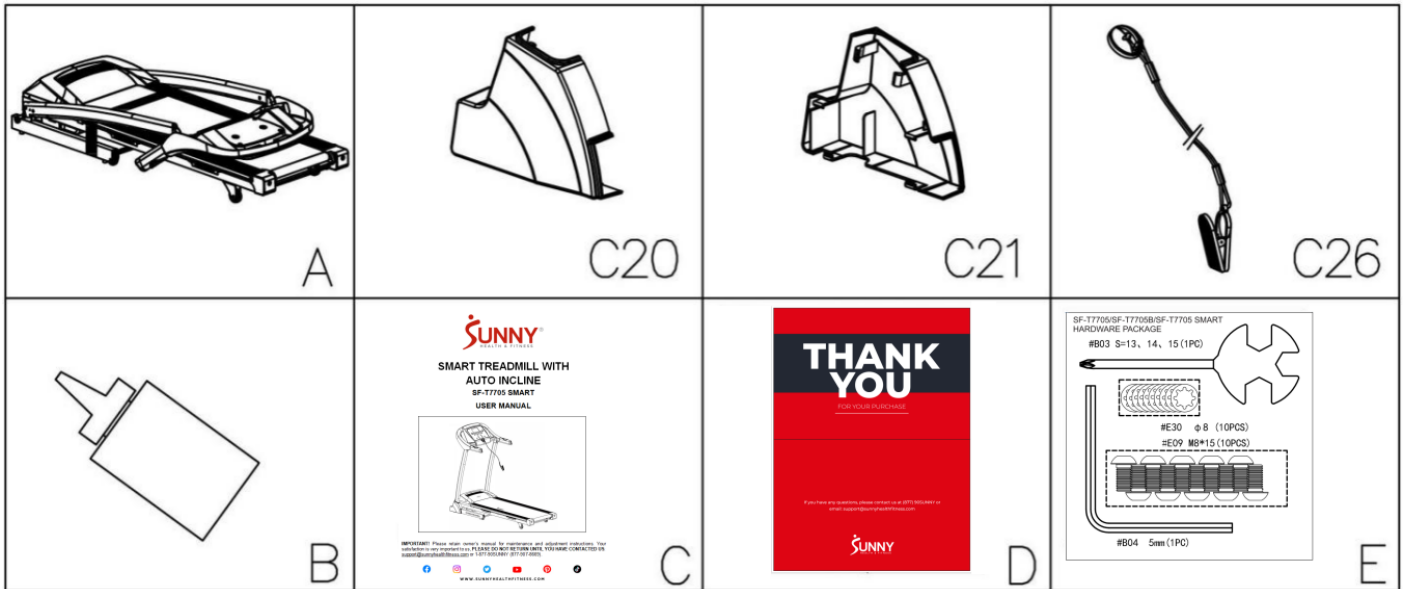

No.	Description	Spec.	Qty.
A	Treadmill		1
C20	Left Upright Tube Cover		1
C21	Right Upright Tube Cover		1
C26	Safety Key		1

No.	Description	Spec.	Qty.
B	Lubricant Oil		1
C	Manual		1
D	Thank You Card		1
E	Hardware Package		1

# HARDWARE PACKAGE

SF-T7705/SF-T7705B/SF-T7705 SMART  
HARDWARE PACKAGE

#B03 S=13、14、15 (1PC)

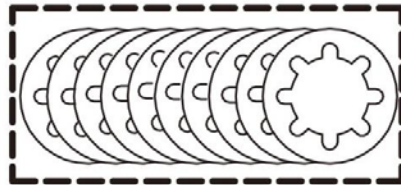
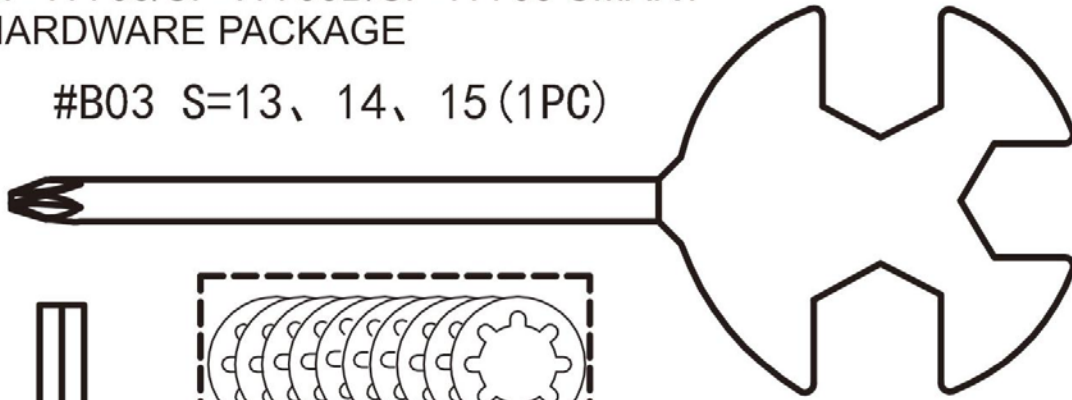

#E30  $\phi$  8 (10PCS)

#E09 M8\*15 (10PCS)

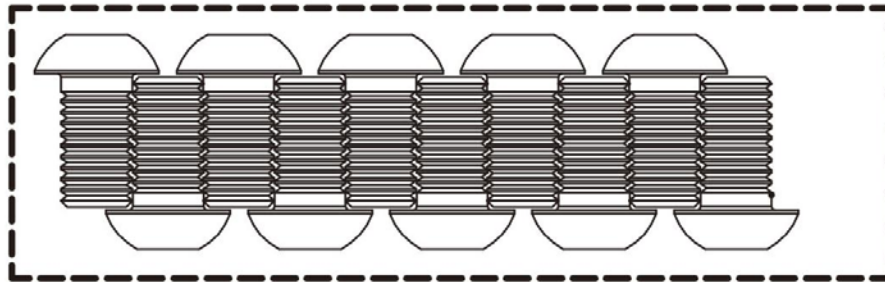

#B04 5mm (1PC)

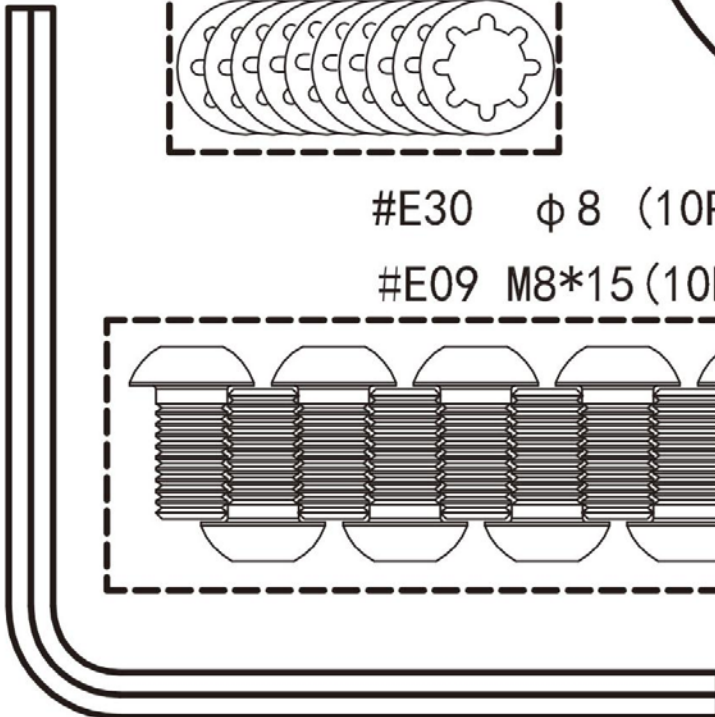

## Ordering Replacement Parts (U.S. and Canadian Customers only)

Please provide the following information in order for us to accurately identify the part(s) needed:

- ✓ The model number (found on cover of manual)
- ✓ The product name (found on cover of manual)
- ✓ The part number found on the "EXPLODED DIAGRAM" (page 22) and "PARTS LIST" (pages 23~24)

Please contact us at [support@sunnyhealthfitness.com](mailto:support@sunnyhealthfitness.com) or 1-877-90SUNNY (877-907-8669).

# ASSEMBLY INSTRUCTIONS

We value your experience using Sunny Health and Fitness products. For assistance with parts or troubleshooting, please contact us at [support@sunnyhealthfitness.com](mailto:support@sunnyhealthfitness.com) or 1-877-90SUNNY (877-907-8669).

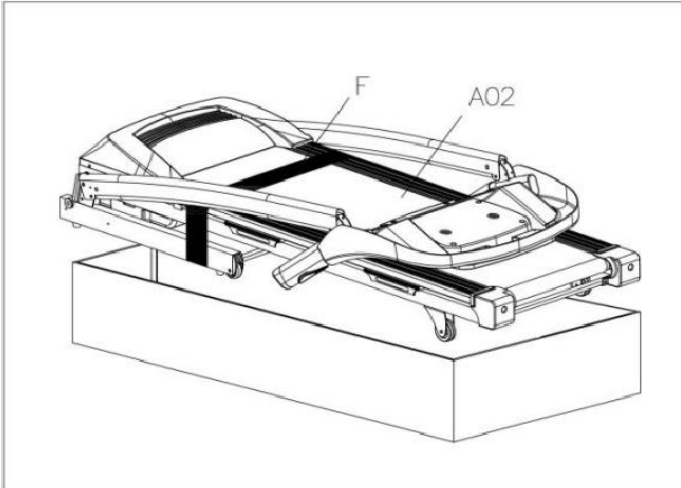

## STEP 1:

Open the carton and remove contents. Place the **Main Frame (No. A02)** on level ground, ensure that you have a work area that is clean and has adequate space.

**Do not cut the Packing Belt (No. F) until the assembly is complete!**

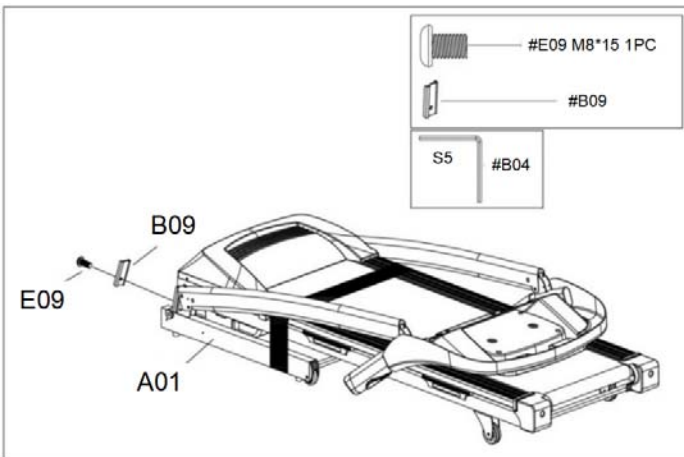

## STEP 2:

Loosen the **Bolt (No. E09)** on the **Base Frame (No. A01)** by using **Allen Wrench (No. B04)** and remove the **Safety Block (No. B09)**.

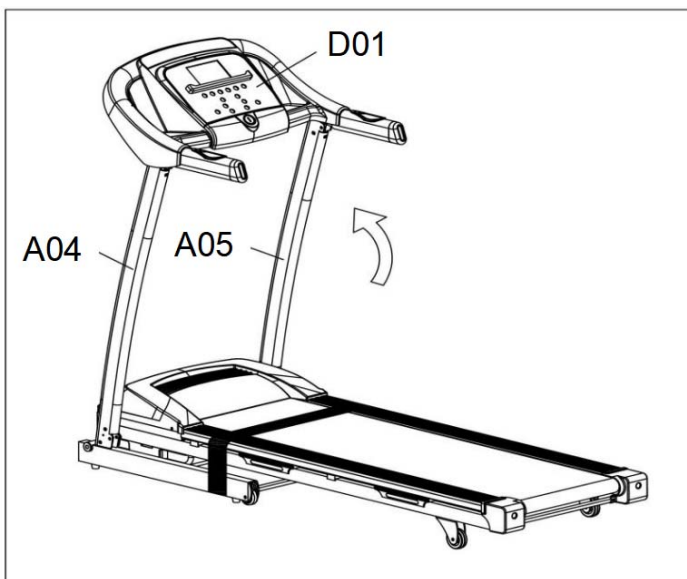

## STEP 3:

Lift the **Console (No. D01)** along with **Left & Right Upright Tubes (No. A04 & No. A05)** upward (in the direction specified by the arrows on the diagram to the left).

**NOTE:** When lifting, avoid puncturing the wires inside the **Left & Right Upright Tubes (No. A04 & No. A05)** as this will cause damage.

We value your experience using Sunny Health and Fitness products. For assistance with parts or troubleshooting, please contact us at [support@sunnyhealthfitness.com](mailto:support@sunnyhealthfitness.com) or 1-877-90SUNNY (877-907-8669).

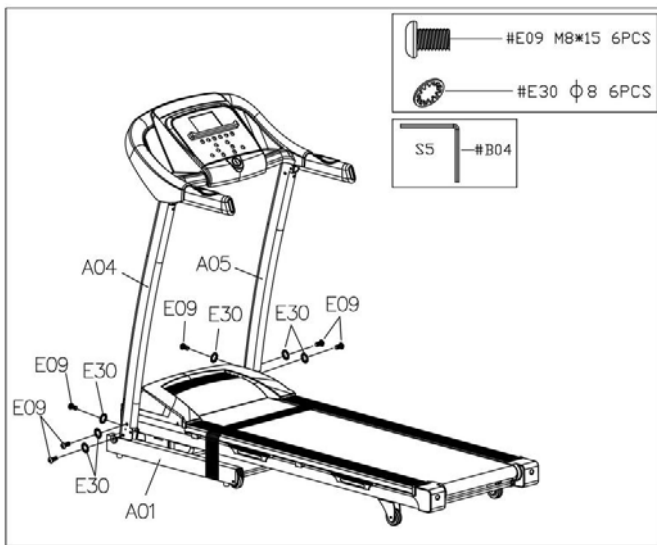

#### STEP 4:

Support the **Left & Right Upright Tubes (No. A04 & No. A05)** with your hands to prevent them from falling.

Attach the **Left & Right Upright Tubes (No. A04 & No. A05)** to the **Base Frame (No. A01)** using 6 **Bolts (No. E09)** and 6 **Washers (No. E30)**. Secure by using **Allen Wrench (No. B04)**.

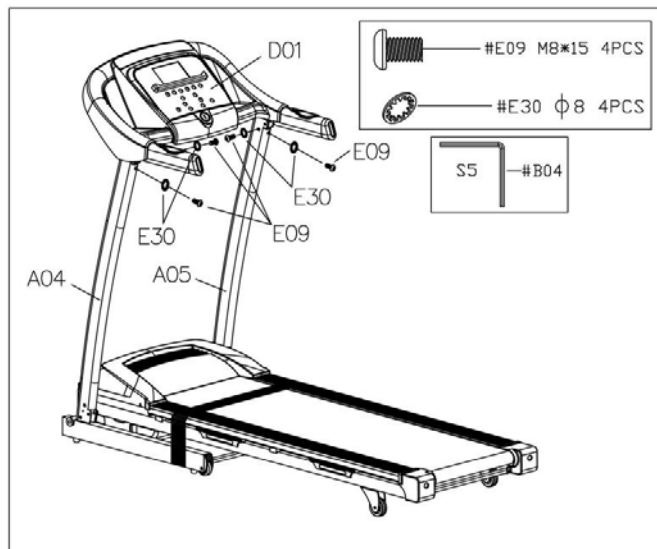

#### STEP 5:

Attach the **Console (No. D01)** to the **Left & Right Upright Tubes (No. A04 & No. A05)** by using 4 **Bolts (No. E09)** and 4 **Washers (No. E30)**. Secure using **Allen Wrench (No. B04)**.

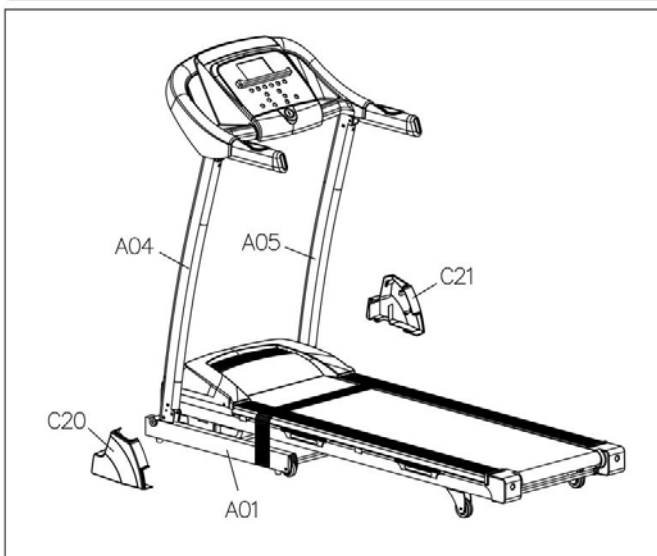

#### STEP 6:

Attach the **Left & Right Upright Tube Covers (No. C20 & No. C21)** to the **Base Frame (No. A01)**.

We value your experience using Sunny Health and Fitness products. For assistance with parts or troubleshooting, please contact us at [support@sunnyhealthfitness.com](mailto:support@sunnyhealthfitness.com) or 1-877-90SUNNY (877-907-8669).

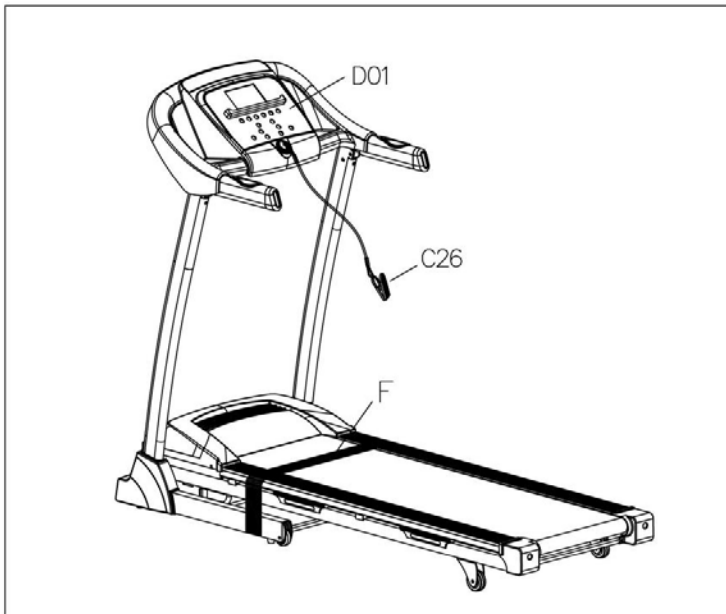

**STEP 7:**

You may now cut the **Packing Belt (No. F)**.

Insert the pin end of **Safety Key (No. C26)** into the **Console (No. D01)**.

*The assembly is complete!*



**IMPORTANT NOTE!**

You will need to lubricate your treadmill before the first use. See *Page 10*.

# MAINTENANCE & CARE

General cleaning will help prolong the life and improve performance of your treadmill. Keep the unit clean and maintained by dusting the components on a regular basis. Cleaning the two exposed sides of the **Running Belt (No. C23)** will prevent dust from accumulating underneath. Keep your running shoes clean so that dirt from the shoes does not wear the **Running Board (No. D20)** and **Running Belt (No. C23)**. Clean the surface of the **Running Belt (No. C23)** with a clean damp cloth. Keep liquids away from electrical parts and **Running Belt (No. C23)**.

To better maintain the treadmill and prolong its life, it is suggested that the treadmill be powered off for 10 minutes every 2 hours and fully powered off whenever not in use.

## **CENTERING THE RUNNING BELT:**

Place the treadmill on level ground and set it at 3-5 MPH to check if the **Running Belt (No. C23)** drifts from the center.

If the **Running Belt (No. C23)** moves to the right, turn the right adjusting bolt  $\frac{1}{4}$  turn *clockwise*, then turn the left adjusting bolt  $\frac{1}{4}$  turn *counter-clockwise*. If the **Running Belt (No. C23)** does not move, repeat this step until it centers. Refer to Figure A.

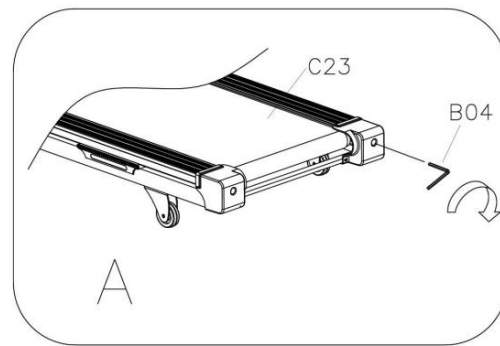

If the **Running Belt (No. C23)** moves to the left, turn the left adjusting bolts  $\frac{1}{4}$  turn *clockwise*, then turn the right adjusting bolt  $\frac{1}{4}$  turn *counter-clockwise*. If the **Running Belt (No. C23)** does not move, repeat this step until it centers. Refer to Figure B.

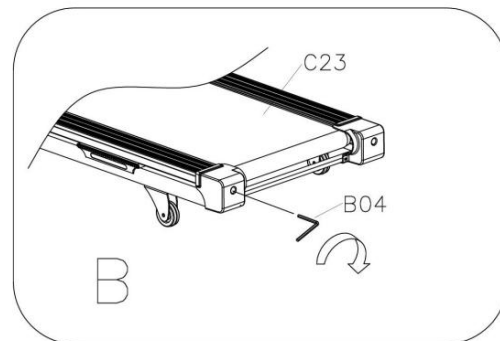

Over time, the **Running Belt (No. C23)** will loosen. To tighten the **Running Belt (No. C23)**, turn the left & right adjusting bolts one full turn *clockwise*, check the tension of the **Running Belt (No. C23)**. Continue this process until **Running Belt (No. C23)** is at the correct tension. Make sure to adjust both sides equally to ensure correct belt alignment. Refer to Figure C.

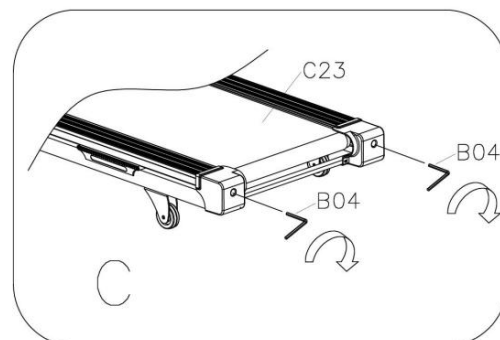

# LUBRICATING THE TREADMILL

## **IMPORTANT NOTE:**

You will need to lubricate your treadmill before the first use.

## **RUNNING BELT & TREADMILL LUBRICANT:**

Lubricating the **Running Board (No. D20)** and **Running Belt (No. C23)** is essential as the friction affects the life span and operations of the treadmill. Inspect the **Running Belt (No. C23)** and **Running Board (No. D20)** regularly. If you find any wear on the **Running Board (No. D20)**, please contact us at: [support@sunnyhealthfitness.com](mailto:support@sunnyhealthfitness.com).

**WARNING:** Always unplug the treadmill from the electrical outlet before cleaning, lubricating, or repairing the unit.

## **HOW TO LUBRICATE:**

1. To apply lubricant, lift one side of the **Running Belt (No. C23)** and apply oil to the middle of the **Running Board (No. D20)**. Next, start the treadmill and place it at the lowest speed setting and allow the oil to spread over the **Running Board (No. D20)**. Repeat this process for the other side.
2. The moving parts should turn freely and quietly. Abnormal moving parts will affect the safety of the equipment. Inspect and tighten bolts regularly.
3. To better maintain the treadmill and prolong its lifespan, it is suggested that maintenance be done on a regular basis.
4. **DO NOT LOOSEN OR MAKE ANY ADJUSTMENTS TO THE RUNNING BELT WHILE APPLYING LUBRICANT.** A loose **Running Belt (No. C23)** will result in the runner sliding off during use, while too tight of a **Running Belt (No. C23)** will negatively affect the motor's performance and create more friction between the roller and **Running Belt (No. C23)**. The most suitable tightness for the **Running Belt (No. C23)** is when it is pulled out **50-75mm** from the **Running Board (No. D20)**.

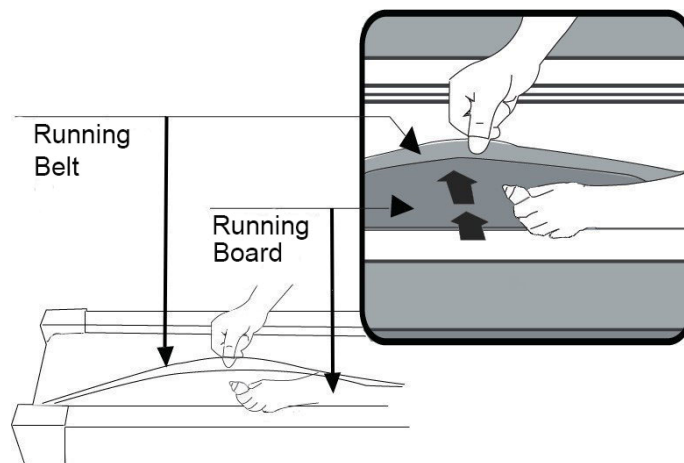

## **The following timetable is recommended:**

Light user (less than 3 hours/ week)	<i>every six months</i>
Medium user (3-5 hours/ week)	<i>every three months</i>
Heavy user (more than 5 hours/ week)	<i>every two months</i>

# FOLDING INSTRUCTIONS

## FOLDING:

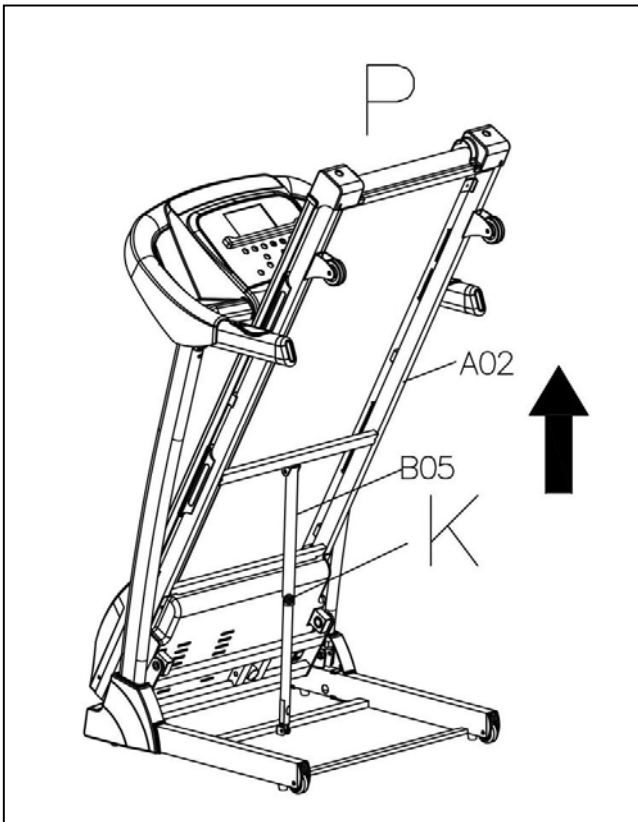

**NOTE:** Please make sure the incline is at ZERO when folding and unfolding.

Place your hand at position “P” and lift up the **Main Frame (No. A02)** until the **Air Pressure Cylinder (No. B05)** “K” locks into the tube.

When the **Air Pressure Cylinder (No. B05)** successfully locks into the tube, you will hear a clicking sound.

## UNFOLDING:

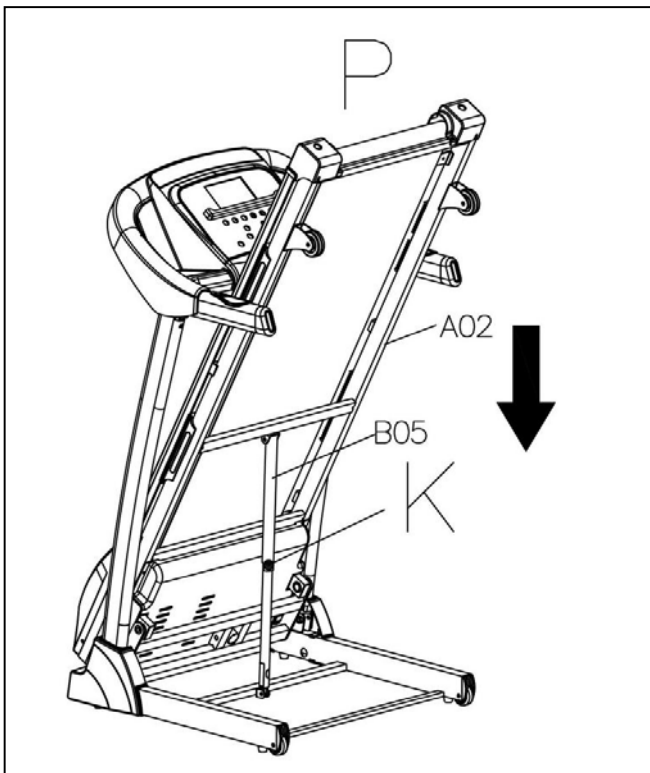

Before lowering the **Main Frame (No. A02)**, ensure that the space directly underneath it is clear of any objects.

Hold the **Main Frame (No. A02)** at position “P” with one hand. Next, using your foot, firmly push against the **Air Pressure Cylinder (No. B05)** “K” and press down on the **Main Frame (No. A02)**. Once the **Main Frame (No. A02)** has been pushed down, it will automatically continue to steadily lower itself until it reaches level ground. (Please keep everyone and all pets away from the treadmill when unfolding the treadmill.)

## HOW TO MOVE THE MACHINE

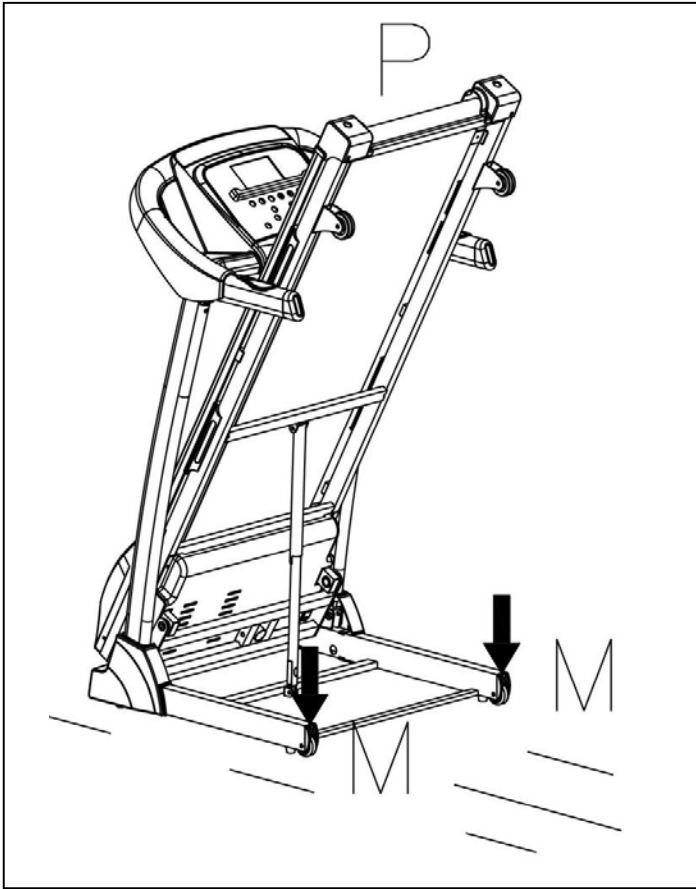

Before attempting to move the treadmill, make sure that it has been properly folded. Unplug the power cord.

To tilt, start by placing one hand at position "P" to support the top end of the treadmill. Next, place one foot at position "M" to hold the bottom end of the treadmill steady. With your foot at "M," slowly tilt the top of the treadmill downward towards the ground. Once the treadmill reaches a low enough point, the transportation wheels of the treadmill will touch the ground.

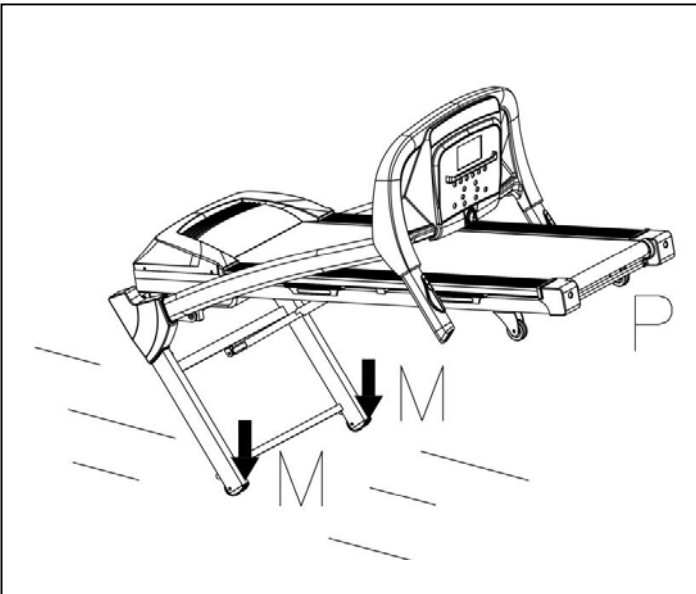

To transport, hold the treadmill at position "P" and tilt until the transportation wheel's "M" are able to move on the ground.

# **IMPORTANT ELECTRICAL INFORMATION**

**WARNING:** This treadmill requires a power source of **10 amps (100-120V)** in order to properly operate. For your safety, as well as the safety of others, please verify that the power source is correct before plugging in the equipment. Any power source above or below this level could cause significant damage to the equipment and/or user.

## **GROUNDING METHODS:**

This product must be grounded. Grounding provides a path of the least resistance for electrical current to reduce the risk of electric shock. The plug must be plugged into an appropriate outlet that is properly installed and grounded in accordance with all local codes and ordinances. Ensure that the product is connected to an outlet which contains the same configuration as the plug. Do not use an adapter for this product.

This product is for use on a nominal 100-120V circuit and has a grounding plug that looks like the plug illustrated in sketch A.

## **DANGER:**

Improper connection of the equipment can result in a risk of electric shock. Check with a qualified electrician or serviceman if you are unsure whether the product has been properly grounded. Do not modify the plug provided with this product. If it will not fit the outlet, have a proper outlet installed by a qualified electrician.

## **WARNING!**

1. **NEVER** use a ground fault circuit interrupt (GFCI) wall outlet with this treadmill. Route the power cord away from all moving parts of the treadmill, including the elevation mechanism and transportation wheels.
2. **NEVER** operate the treadmill using a generator or UPS power supply.
3. **NEVER** remove any cover on the treadmill without first disconnecting power cord.
4. **NEVER** expose the treadmill to rain or moisture. This treadmill is not designed for outdoor use or use in any high humidity environment.

### **GROUNDING METHOD**

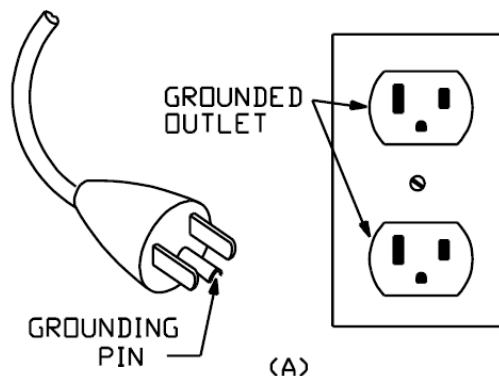

# THE DISPLAY CONSOLE

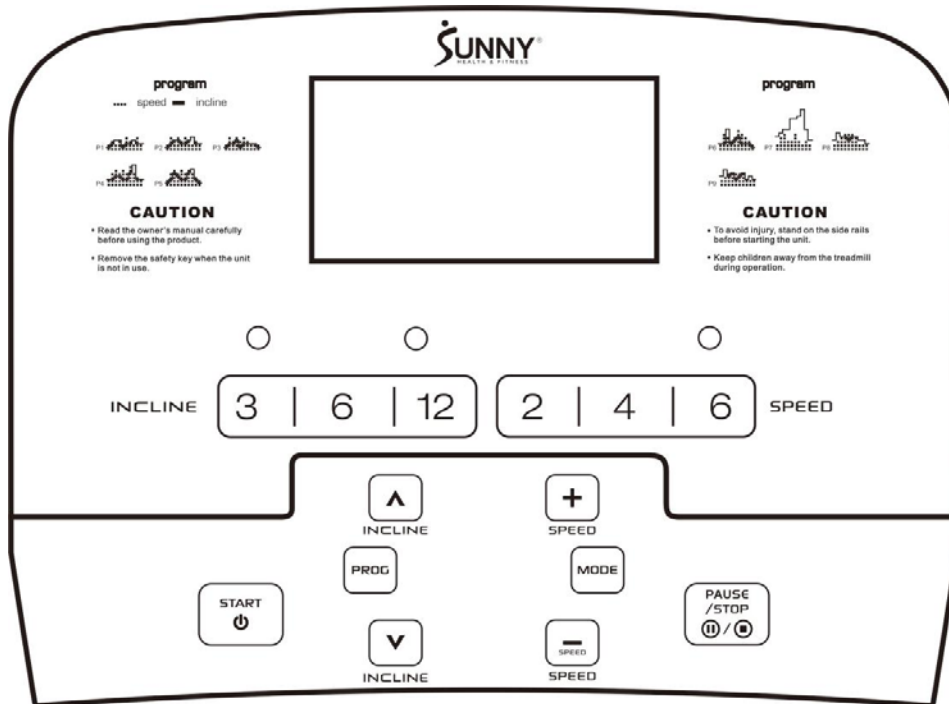





## QUICK START:

1. Insert the pin end of the **Safety Key (No. C26)** into the **Console (No. D01)**.
2. Press the START button, and the system will automatically display a 3 second countdown. Once the countdown reaches zero, the **Running Belt (No. C23)** will start at the initial **default speed of 0.5 MPH**.
3. To adjust the speed, you can use the SPEED +/- BUTTONS or QUICK SPEED BUTTONS 2, 4, & 6 MPH.
4. To adjust the incline, you can use the INCLINE UP/DOWN BUTTONS or QUICK INCLINE BUTTONS 3%, 6%, & 12%.

**\*NOTE: The maximum speed on this treadmill is 9 MPH.**

## CONTROL FUNCTIONS:

1. Press the  Speed Button to reduce the running speed.
2. Press the  Speed Button to increase the running speed.
3. Press the  Incline Button to reduce the incline level.
4. Press the  Incline Button to increase the incline level.
5. Pressing a Quick Speed Button will adjust the speed to the corresponding speed indicated (2, 4, or 6 MPH).
6. Press the 3%, 6%, 12% Quick Incline Keys to instantly change incline to 3%, 6%, 12%.
7. Pressing the Stop Button will stop the running belt of the treadmill.
8. Holding the Pulse Sensors located on the handles with both hands for 5 seconds will calculate and display the runner's heartbeats per minute (BPM) on the computer display screen.

## WINDOW DISPLAY:

**SPEED/ PULSE:** The speed range is **0.5-9.0 MPH**. 0.5 MPH is the default running speed.

When the runner holds both hands on the pulse sensors (located on the handles), the system will calculate the runner's heartbeat and display it in this window. The pulse range is 50-200 beats/min.

**NOTE: This data is just for reference and cannot be used for medical purposes.**

**TIME:** Displays the time elapsed (0:00-99:59 MINS). If the time reaches 99:59, the treadmill will stop smoothly and display "End" then automatically reset to 0:00 after 5 seconds.

When in Countdown Mode, it will count from the setting time to 0:00. When the clock reaches 0:00, the treadmill will stop smoothly and display "End" then automatically reset itself after 5 seconds.

Maximum Countdown time is 99:00 minutes: seconds.

**DISTANCE:** Displays the distance traveled (0.0-99.9 MILES). When the clock reaches 99.9, it will reset to 0.00 and begin counting again from 0.0. When in Countdown Mode, it will count down from the setting data to 0.00. When it reaches 0.00, the treadmill will stop smoothly and display "End" and automatically reset to the initial setting after 5 seconds. When setting PROGRAMS, the speed is programmed in intervals; PROGRAMS are from P1-P9-FAT.

**CALORIES/INCLINE:** Displays the number of calories burned from 0 to 999 KCAL and the incline level from 0-15. When the count reaches 999, it will reset and start back from 0. When in Countdown Mode, it will count down from the desired setting to 0. Once it reaches 0, the treadmill will stop smoothly and display "End", then automatically reset to the initial setting after 5 seconds.

**STEPS:** Counts steps that the user has walked. When it displays steps, it will count from 0 to 99999. When it reaches 99999, it will count again from 0.

**MATRIX:** The matrix window will display a 0.25 MILES running track. Once you finish running the lap, the treadmill will beep and show the number of laps you've completed.

PROGRAMS	Initial	Default Value	Set Range	Display Range
TIME (MIN:SECOND)	0:00	10:00	5:00-99:00	0:00—99:59
INCLINE (SECTION)	0	0	0-15	0-15
SPEED (MPH)	0.5	0.5	0.5-9	0.5-9
DISTANCE (MILE)	0.00	1.00	0.50-99.9	0.00—99.9
PULSE (BPM)	P	N/A	N/A	50-200
CALORIE (KCAL)	0	50	10-999	0—999

## FUNCTION KEYS:

**PROGRAM:** Press the PROGRAM button to set your desired interval setting. Programs are displayed as P1-P9 and FAT and the various intervals are shown on the face of the treadmill. P1-P9 are preset programs.

**MODE:** When stopped, press this button to select a Countdown Mode.

10:00 MINS is the set Countdown for TIME.

1.0 MILE is the set Countdown for DISTANCE.

50 KCAL is the set Countdown for CALORIES.

When setting each Countdown Mode, you can press the speed +/- buttons to increase or decrease from the set data. Press START to start the treadmill.

**START:** To start the treadmill, insert the pin end of the safety key into the console and then press the START button. This treadmill requires the safety key in order to start. 0.5 MPH is the default start speed.

**STOP/PAUSE:** This button has functions of STOP and PAUSE. During running, press this button, the treadmill will pause, and all data will be kept, window will show "PAU"; Under pause mode, if you

press "START" button, the treadmill will continue to work. If you press "STOP" button, the treadmill will stop, and all data recover to initial setting.

**SPEED +/-:** Press the +/- buttons to increase or decrease the speed in increments of 0.1 MPH. Pressing and holding either of these buttons for a duration of over ½ of a second will increase or decrease the speed continually.

**INCLINE UP/DOWN:** Press this button to adjust incline. When the treadmill is running, press the Up & Down buttons to increase or decrease the incline in increments of 1/time. Pressing and holding either of these buttons for duration of over ½ a second will increase or decrease the incline continually. The incline levels range from 0-15.

**2, 4, & 6 (QUICK SPEED BUTTONS):** These buttons are preset to 2, 4, or 6 MPH speeds for convenience.

**3%, 6%, 12% (QUICK INCLINE BUTTONS):** These buttons are quick incline presets which allow you to select an automatic running incline of 3%, 6%, 12% instantly with the push of a button.

## APP CONNECTION:

1. Scan to download SunnyFit from the app store:



2. Ensure that the Bluetooth function is turned on from your mobile device.
3. If this is your first time using the SunnyFit app, follow the in-app instructions to register for your free SunnyFit account and log in.
4. Begin any workout activity that matches your smart equipment, then follow the onscreen prompts to search for and connect to your smart equipment.
5. When connected, your stats and records will be displayed at the end of your course/session and recorded in your account profile!

## LUBRICATION REMINDER:

Your treadmill needs lubrication maintenance every 188 MILES. The system will release a beeping sound every 10 seconds and display an "OIL" icon on your LCD display to remind you when it is time. Please read LUBRICATING THE TREADMILL on *Page 10* to learn the proper steps to lubricate your treadmill. Apply the lubricant to the middle of the running board on both sides. After application, press and hold the STOP button for 3 seconds to clear the "OIL" reminder.

## INTERVAL PROGRAMS (P1-P9):

Press the PROGRAM button to select an interval setting. Programs are displayed as P1-P9. Select the desired program, and the console will display a countdown starting from 10:00 MINS, press SPEED +/- or INCLINE UP/DOWN buttons if you wish to increase or decrease the exercise time. Press the START button to start the interval program. The interval program is divided into 10 sections. Each exercise time equals the setting time divided by 10. When the speed enters the next interval, the treadmill will beep, and the speed will be changed according to the set interval. Press SPEED +/- or INCLINE UP/DOWN buttons to change the SPEED and INCLINE. After finishing one program, the system will beep and display "End." The treadmill will gradually come to a stop, then automatically reset to the initial setting after 5 seconds.

		TIME INTERVAL= setting time/10									
		1	2	3	4	5	6	7	8	9	10
P1	SPEED	1.2	2.5	1.8	2.5	1.8	3.1	2.5	1.2	3.1	1.8
	INCLINE	1	2	3	3	1	2	2	3	2	2
P2	SPEED	1.2	3.1	2.5	3.7	2.5	3.7	2.5	1.2	2.5	1.2
	INCLINE	1	2	3	3	2	2	3	4	2	2
P3	SPEED	1.2	3.1	2.5	3.1	2.5	3.1	2.5	1.2	1.8	1.2
	INCLINE	1	2	2	3	1	2	2	2	2	1
P4	SPEED	1.8	3.7	4.3	3.1	5	3.1	5.6	3.7	2.5	1.8
	INCLINE	2	2	3	3	2	2	4	6	2	2
P5	SPEED	1.8	3.7	4.3	3.1	5	3.7	4.3	3.7	2.5	1.8
	INCLINE	1	2	4	3	2	2	4	5	2	1
P6	SPEED	1.2	5	3.7	2.5	3.1	5.6	4.3	3.1	2.5	1.8
	INCLINE	2	2	6	2	3	4	2	2	2	1
P7	SPEED	1.2	3.7	4.3	2.5	2.5	4.3	2.5	1.2	2.5	1.2
	INCLINE	4	5	6	6	9	9	10	12	6	3
P8	SPEED	1.2	2.5	3.7	5	4.3	5	3.7	1.2	1.8	1.2
	INCLINE	3	5	4	4	3	4	4	3	3	2
P9	SPEED	1.2	2.5	3.1	3.1	3.7	3.1	3.7	1.8	1.8	1.2
	INCLINE	3	5	3	4	2	3	4	2	3	2

### BODY MASS INDEX:

Press the PROGRAM button until the window displays FAT to access Body Mass Index. Press MODE to enter F-1, F-2, F-3, F-4, F-5.

**F-1 SEX, F-2 AGE, F-3 HEIGHT, F-4 WEIGHT, F-5 is Body Mass Index**

Press SPEED +/- buttons to set F1-F4 (refer to the chart below). Once you have finished setting F1-F4, press MODE. This will enter you into the set up for F-5 (Body Mass Index). To set F-5, hold the pulse sensors located on the handrails with both hands and hold them for 3 seconds. The window will display your Body Mass Index. The Body Mass Index is used to test the relation between your height and weight. It is only for reference not suitable for medical use. The Body Mass Index is suitable for both male and female.

**NOTE:** General **Body Mass Index** score is **20-25%**

Underweight	Below 19.0
Normal	19.0 – 25.0
Overweight	26.0 – 29.0
Obesity	30.0 – and above

### BODY MASS INDEX (BMI) CHART:

F-1	Sex	01 Male	02 Female
F-2	Age	10-----99	
F-3	Height	40----80 INCHES	
F-4	Weight	44-----330 LBS	
F-5	BMI	≤19	Underweight
	BMI	=(20---25)	Normal Weight
	BMI	=(26---29)	Overweight
	BMI	≥30	Obesity

## TREADMILL FUNCTIONS

### SAFETY LOCK FUNCTION:

Removing the **Safety Key (No. C26)** from the console while the treadmill is running will cause it to stop immediately. Once the treadmill reaches a full stop, the window display of the console will show “- - -” and the buzzer will beep 3 times. To start the treadmill again, insert the pin end of the **Safety Key (No. C26)** into the console and press the START button.

### POWER SAVE FUNCTION:

When the treadmill has been inactive for 10 minutes, it will enter Power Saving Mode. While the treadmill is in this mode, the window display of the console will be turned off. To turn it back on, press any button.

### **I** POWER ON:

Flick the power switch to this symbol to turn on the treadmill.

### **O** POWER OFF:

Flick the power switch to this symbol to turn the treadmill off at any time. This includes during exercise.

### SAFETY NOTE:

We recommend that you maintain a slow speed at the beginning of a session and hold the handrails until you have become familiar with the treadmill.

Insert the pin end of the **Safety Key (No. C26)** into the **Console (No. D01)** and attach the opposite end (containing the safety clip on it) to your clothing before starting your workout. To end your workout, press the STOP button or remove the **Safety Key (No. C26)** and the treadmill will stop immediately.

# EXERCISE INSTRUCTIONS

## **GETTING STARTED:**

Before starting any exercise program, you should consult your physician to determine if you have any medical or physical conditions that could put your health and safety at risk or prevent you from using the equipment properly.

Be aware of your body's signals. Incorrect or excessive exercise can damage your health.

Stop exercising immediately if you experience any of the following symptoms: pain, tightness in your chest, irregular heartbeat, shortness of breath, lightheadedness, dizziness, or feelings of nausea.

Get to know your treadmill. Before attempting to use the treadmill take some time to stand alongside and familiarize yourself with the controls.

1. Once you get on, you can stand with your feet on the side rails and stabilize yourself by holding onto the handrails.
2. Next, attach the clip end of the **Safety Key (No. C26)** to your clothes and insert the magnetic end of the key into the **Console (No. D01)**.
3. Press the START button to start the treadmill.
4. The treadmill will start at the system default setting speed of **0.5 MPH**. When you feel comfortable, you may slowly increase this speed.
5. When you are finished with your exercise, press the STOP button to stop the treadmill or you can remove the pin end of the **Safety Key (No. C26)** to stop the treadmill.

## TROUBLESHOOTING

PROBLEM	POSSIBLE CAUSE	SUGGESTED ACTION
Treadmill will not start	Not plugged in.	Plug cord into outlet.
	<b>Safety Key (No. C26)</b> is not inserted.	Insert <b>Safety Key (No. C26)</b> .
Running belt not centered	Running belt tension is not correct on the left or right sides of the running board.	Tighten the left and right adjusting bolts of the rear roller (See page 9).
Computer not working	Wires from the console and bottom control board are not properly connected.	Check wire connections from the console to the bottom control board.
	Transformer is damaged.	If the transformer is damaged, contact customer service.
E01 or E13: Message failure	Wires from the console and bottom control board are not properly connected.	Check wire connections from the console to the bottom control board. If the wire has been punctured or damaged, you will need to replace it. If the problem is not rectified, you may need to replace the control board.
E02: Burst clash protection	Incoming voltage is lower than 50% of the required voltage.	Check that the incoming power supply is the correct voltage.
E03: No speed sensor signal	Speed sensor signal cannot be received by the control board.	Check that the sensor wire is properly connected. If damaged, replace wire. Check to see if the magnetic sensor is damaged, replace if necessary.
E05: Current overload protection (Self Protecting System)	The incoming voltage is too low or too high. The control board is damaged.	Restart the treadmill. Check the incoming voltage to ensure it is correct. Check the control board, replace if damaged.
	A moving part of the treadmill is stuck and therefore, the motor is unable to rotate properly.	Inspect moving parts of the treadmill to ensure that they are operating correctly. Check the motor, listen for strange noise, and check for a burning smell. Replace the motor if necessary.

E06: Motor Abnormality	The motor wire is not connected, or the motor is damaged.	Check motor wires to see if the motor is connected. If the wire has been punctured or damaged, you will need to replace it. If the problem is not rectified, you may need to replace the motor.
E08: Control Board Abnormality	The control board is not connected.	Check the upper and middle wires to see if the control board is connected. If the wire has been punctured or damaged, you will need to replace it. If the problem is not rectified, you may need to replace the control board.
E10: Motor Abnormality	The motor is damaged, or a moving part of the treadmill is stuck and therefore the motor is unable to rotate properly.	Inspect moving parts of the treadmill to ensure that they are operating correctly. Replace the motor if necessary.

**NOTE:**

1. If you are having trouble connecting your smart equipment, visit [www.sunnyfit.com/guide](http://www.sunnyfit.com/guide) or scan the QR code below:



2. If you require additional support, please contact [support@sunnyfit.com](mailto:support@sunnyfit.com).



# PARTS LIST

No.	Description	Specification	Qty.
A01	Base Frame		1
A02	Main Frame		1
A03	Computer Bracket		1
A04	Left Upright Tube		1
A05	Right Upright Tube		1
A06	Incline Bracket		1
A07	Motor Bracket		1
B01	Front Roller		1
B02	Rear Roller		1
B03	Spanner w/ Screw Driver	S=13,14,15	1
B04	Allen Wrench	5mm	1
B05	Air Pressure Cylinder		1
B06	Turning Bushing		2
B07	Incline Bushing		2
B08	Metal Sheet		2
B09	Safety Block		1
C01	Console Top Cover		1
C02	Console Panel		1
C03	Motor Top Cover		1
C04	Motor Bottom Cover		1
C05	Left Rear Cover		1
C06	Right Rear Cover		1
C07	Side Rail		2
C08	Square Cushion		4
C09	Silicone Pad		4
C10	Ring Protecting Wire Plug		2
C11	transportation Wheel		2
C12	Power Wire Buckle		1
C13	Cone Shape Foot Pad		4
C14	Adjustable Wheel		2
C15	Foam		2
C16	End Cap		2
C17	Oval End Cap		2
C18	Blue Cushion		2
C19	Console Back Cover		2
C20	Left Upright Tube Cover		1
C21	Right Upright Tube Cover		1
C22	Wheel Cover		2
C23	Running Belt		1
C24	Motor Belt		1
C25	Safety Key Socket		1
C26	Safety Key		1
C27	Holder		1

No.	Description	Specification	Qty.
C28	End Cap		2
D01	Console		1
D02	Control Board		1
D03	Upper Signal Wire		1
D04	Middle Signal Wire		1
D05	Lower Signal Wire		1
D06	Hand Pulse with Incline		1
D07	Hand Pulse with Speed		1
D08	Hand Pulse Upper Wire		1
D09	Hand Pulse Lower Wire		2
D10	Speed Sensor		1
D11	Safety Accessory		1
D12	DC Motor		1
D13	AC Single Line	Brown	1
D14	AC Single Line	Blue	2
D15	Incline Motor		1
D16	Power Wire		1
D17	Square Switch		1
D18	Magnetic Ring		1
D19	Magnetic Core		1
D20	Running Board		1
D21	Overload Protector		1
E01	Nut	M6	2
E02	Nut	M8	6
E03	Nut	M10	4
E04	Bolt	M10*100	1
E05	Bolt	M10*65	2
E06	Bolt	M10*50	2
E07	Bolt	M10*45	1
E08	Bolt	M8*30	1
E09	Bolt	M8*15	13
E10	Bolt	M8*20	4
E11	Bolt	M8*30	1
E12	Bolt	M8*35	2
E13	Bolt	M8*38	2
E14	Bolt	M8*40	4
E15	Bolt	M8*45	1
E16	Bolt	M6*55	3
E17	Bolt	M6*35	6
E18	Bolt	M5*8	5
E19	Bolt	M5*12	2
E20	Screw	ST4.2*55	2
E21	Screw	ST4.2*20	4

No.	Description	Specification	Qty.
E22	Screw	ST4.2*12	16
E23	Screw	ST4.2*12	15
E24	Screw	ST3.5*10	8
E25	Screw	ST3.5*8	2
E26	Screw	ST2.9*4	4
E27	Screw	ST2.9*6.0	14
E28	Screw	ST2.9*8	3
E29	Washer	Φ6	3
E30	Washer	Φ8	16
E31	Washer	Φ8	6
E32	Flat Washer	Φ8	7

No.	Description	Specification	Qty.
E33	Big Washer	Φ10*Φ26*2.0	4
E34	Washer	Φ10	2
E35	Flat Washer	Φ10	2
E36	Screw	ST2.6*8	2
F01	Filter		1
F02	AC Single Line	Brown	1
F03	AC Single Line	Blue	1
F04	Grounding Wire		1
F05	Bluetooth Mold		1
F06	Bluetooth Wire		1

Version 1.5

**CONNECT**  
With us

## DOWNLOAD

Track your fitness progress & join  
**FREE** workout courses!

Download **SUNNYFIT** today!



---

## FOLLOW

Find us on social media @sunnyhealthfitness

 @sunnyhealthfitness

 @sunnyhealthandfitness

 @sunnyhealthfit

 /sunnyhealthfitness

 /sunnyhealthfitness

 /sunnyhealthandfitness

[www.sunnyhealthfitness.com](http://www.sunnyhealthfitness.com)