

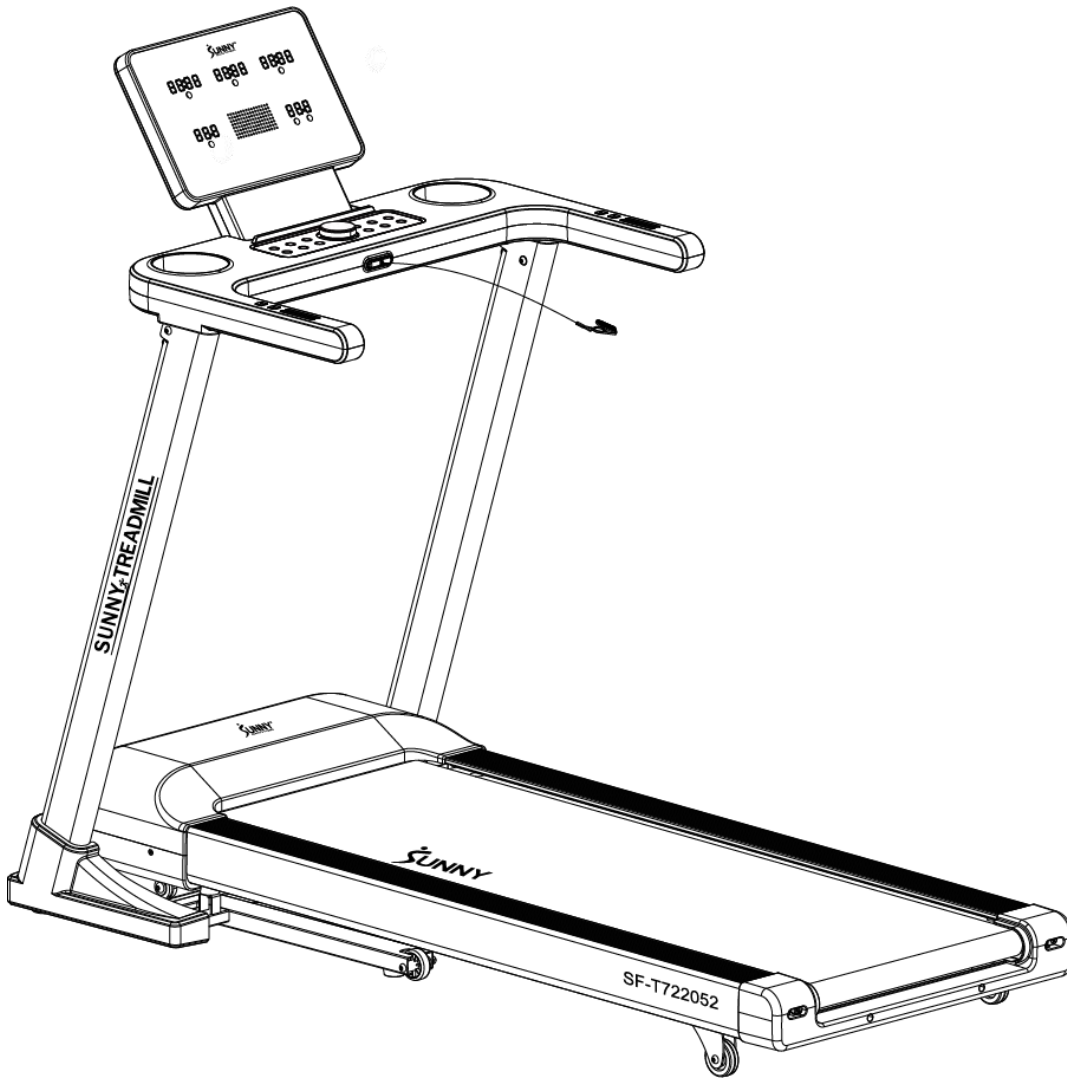

User Manual



Astra Elite Smart Auto Incline Brushless Motor Treadmill

SF-T722052

EN

IMPORTANT! Please retain owner's manual for maintenance and adjustment instructions. Your satisfaction is very important to us, **PLEASE DO NOT RETURN UNTIL YOU HAVE CONTACTED US.**

Important Safety Information

When using an electrical appliance, basic precautions should always be followed, including the following:

Read all instructions before using (this appliance).

DANGER -To reduce the risk of electric shock:

Always unplug this appliance from the electrical outlet immediately after using and before cleaning.

WARNING - To reduce the risk of burns, fire, electric shock, or injury to persons:

1. An appliance should never be left unattended when plugged in. Unplug from outlet when not in use, and before putting on or taking off parts.
2. This appliance is not intended for use by persons with reduced physical, sensory, or mental capabilities, or lack of experience and knowledge, unless they have been given supervision or instruction concerning use of the appliance by a person responsible for their safety. Keep children under the age of 13 away from this machine.
3. Use this appliance only for its intended use as described in this manual. Do not use attachments not recommended by the manufacturer.
4. Never operate this appliance if it has a damaged cord or plug, if it is not working properly, if it has been dropped or damaged, or dropped into water. Please contact Customer Service at support@sunnyhealthfitness.com.
5. Do not carry this appliance by supply cord or use cord as a handle.
6. Keep the cord away from heated surfaces.
7. Never operate the appliance with the air openings blocked. Keep the air openings free of lint, hair, and the like.
8. Never drop or insert any object into any opening.
9. Do not use outdoors. Household use only.
10. Do not operate where aerosol (spray) products are being used or where oxygen is being administered.
11. To disconnect, turn all controls to the off position, then remove plug from outlet.
12. CAUTION: Risk of Injury to Persons - To Avoid Injury, use extreme caution when stepping onto or off of a moving belt. Read Instruction Manual Before Using.
13. Connect this appliance to a properly grounded outlet only. See Grounding Instructions.
14. REMOVE CONTROL BOX (OR KEY, OR SAFETY PIN, AS APPLICABLE) WHEN NOT IN USE, AND STORE OUT OF REACH OF CHILDREN.
15. Do not operate under blanket or pillow. Excessive heating can occur and cause fire, electric shock, or injury to persons.

SAVE THESE INSTRUCTIONS

Caution: The user is cautioned that changes or modifications not expressly approved by the party responsible for compliance could void the user's authority to operate the equipment.

This device contains license-exempt transmitter(s)/receiver(s) that comply with Innovation, Science and Economic Development Canada's license-exempt RSS(s) and Part 15 of the FCC Rules. Operation is subject to the following two conditions:

- 1) This device may not cause interference.
- 2) This device must accept any interference, including interference that may cause undesired operation of the device.

NOTE: This equipment has been tested and found to comply with the limits for a Class B digital device, pursuant to Part 15 of the FCC Rules. These limits are designed to provide reasonable protection against harmful interference in a residential installation. This equipment generates, uses, and can radiate radio frequency energy and, if not installed and used in accordance with the instructions, may cause harmful interference to radio communications. However, there is no guarantee that interference will not occur in a particular installation.

If this equipment does cause harmful interference to radio or television reception, which can be determined by turning the equipment off and on, the user is encouraged to try to correct the interference by one or more of the following measures:

- Reorient or relocate the receiving antenna.
- Increase the separation between the equipment and receiver.
- Connect the equipment into an outlet on a circuit different from that to which the receiver is connected.
- Consult the dealer or an experienced radio/TV technician for help.

FCC Radiation Exposure Statement:

This equipment complies with FCC radiation exposure limits set forth for an uncontrolled environment. This equipment should be installed and operated with a minimum distance of 20cm between the radiator and your body.

This transmitter must not be co-located or operating in conjunction with any other antenna or transmitter.

Important Safety Information

We thank you for choosing our product. To ensure your safety and health, please use this equipment correctly. It is important to read this entire manual before assembling and using the equipment. Safe and effective use can only be achieved if the equipment is assembled, maintained, and used properly. It is your responsibility to ensure that all users of the equipment are informed of all warnings and precautions.

1. Before starting any exercise program, you should consult your physician to determine if you have any medical or physical condition that could put your health and safety at risk or prevent you from using the equipment properly. Your physician's advice is essential if you are taking medication that affects your heart rate, blood pressure, or cholesterol level.
2. Be aware of your body's signals. Incorrect or excessive exercise can damage your health. Stop exercising if you experience any of the following symptoms: pain, tightness in your chest, irregular heartbeat, shortness of breath, lightheadedness, dizziness, or feelings of nausea. If you do experience any of these conditions, you should consult your physician before continuing with your exercise program.
3. Keep children and pets away from the equipment.
4. Use the equipment on a solid, flat level surface with a protective cover for your floor or carpet. To ensure safety, the equipment should have at least 8 feet (240cm) of free space behind it and 2 feet (60cm) on each side. Do not place the treadmill on any surface that blocks air openings. To protect the floor or carpet from damage, place a mat under the treadmill.
5. Ensure that all nuts and bolts are securely tightened before using the equipment. The safety of the equipment can only be maintained if it is regularly examined for damage and/or wear and tear.
6. Always use the equipment as indicated. If you find any defective components while assembling or checking the equipment, or if you hear any unusual noises coming from the equipment during exercise, discontinue use of the equipment immediately and do not use until the problem has been rectified.
7. Wear suitable clothing while using the equipment. Avoid wearing loose clothing that may become entangled in the equipment.
8. Do not place fingers or objects into the moving parts of the equipment.
9. The maximum weight capacity of this unit is 300 lbs (135 kg).
10. This equipment is not suitable for therapeutic use.
11. To avoid bodily injury and/or damage to the product or property, proper lifting and moving are required.
12. Your product is intended for use in cool and dry conditions. You should avoid storage in extreme cold, hot, or damp areas as this may lead to corrosion and other related problems.
13. This equipment is designed for indoor and home use only; it is not intended for commercial use!

Important Operating Information

1. Insert the power plug directly into the socket.
2. Read the manual before operating the equipment.
3. Changes in speed do not occur immediately. Set your desired speed using the adjustment keys on the main console. The speed will increase gradually.
4. While on the treadmill, move with caution as distractions may cause you to lose balance and stray from walking in the center of the belt. This may result in serious injury.
5. This unit starts at a very low speed. To begin use, hold onto the handrails, and stand on the side rails while it starts up, then step onto the belt once it is in motion.
6. Always hold the handrail when making changes in the settings.
7. A safety key is provided for emergency use. The machine will function only if the safety key is inserted into the computer console. In case of emergency, remove the safety key to immediately stop the belt and shut off the treadmill. The display screen will reset once the safety key is reinserted.
8. The console control keys are precisely set and require very little finger pressure to use. To avoid damaging these keys, do not use excessive pressure when operating these controls.
9. This equipment is designed for adult use only! Children should not be allowed to use or play near this equipment. When present, children should always be supervised by an adult.
10. Women who are pregnant or nursing should consult a physician before attempting to begin any exercise program.
11. Always stay hydrated during and after exercise.



IMPORTANT NOTE:

The running belt must be lubricated before the first use! Please see *Page 11* for instructions on how to properly apply lubricant.

Statement Of Purpose

The treadmill is a cardio workout machine that provides indoor running at various speeds.

Waste Disposal



Sunny Health & Fitness products are recyclable. At the end of its useful life please dispose of this article correctly and safely (local refuse sites).

EU Declaration Of Conformity







You can find the declaration of conformity at the following link:
<https://sunnyhealthfitness.com/pages/declaration-of-conformity>

Technical Data

Connectivity: Bluetooth LE
Frequency Range: 2400~2483.5Mhz
Transmitting Power: 0dBm

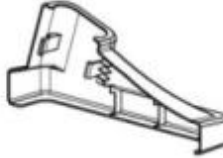
Pre-Assembly Check List

When you open the carton, you will find the following parts:

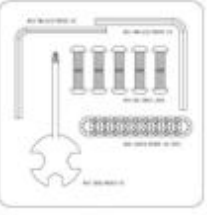
 <p>A</p>	 <p>C05</p>	 <p>C06</p>
 <p>E12</p>	 <p>E18</p>	 <p>T01</p>
 <p>B</p>	 <p>D</p>	

No.	Description	Spec.	Qty.
A	Treadmill		1
C05	Left Upright Tube Cover		1
C06	Right Upright Tube Cover		1
E12	Safety Key		1
E18	Power Wire		1
T01	Lubrication Oil		1
B	Manual		1
D	Hardware Package		1

Hardware Package

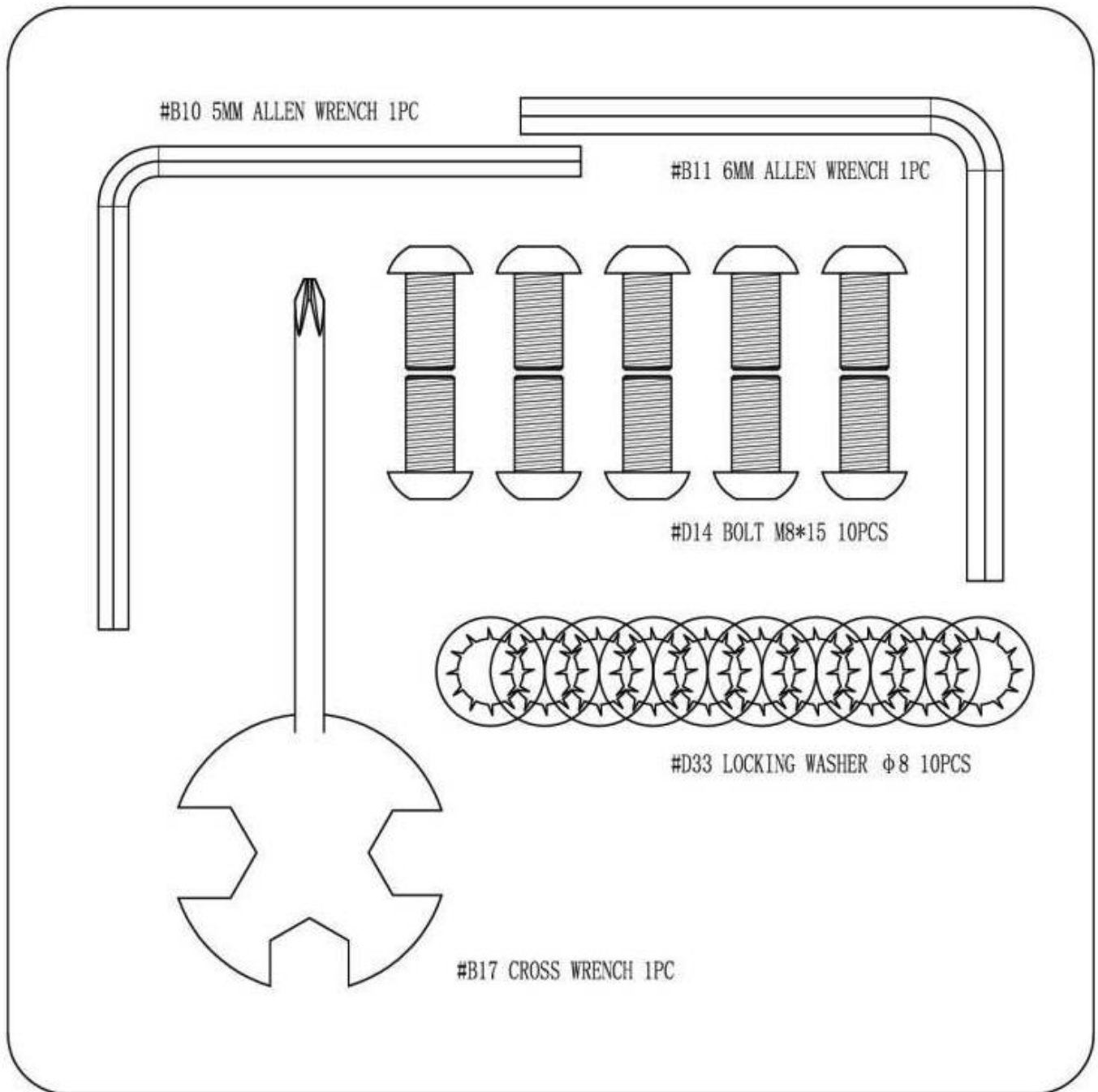

Ordering Replacement Parts

Please provide the following information in order for us to accurately identify the part(s) needed:

- ✓ The model number
- ✓ The product name
- ✓ The part number

Please contact us at support@sunnyhealthfitness.com or 1-877-90SUNNY (877-907-8669).

Warning Labels

CAUTION

Keep hands and feet away from this area while treadmill is running.

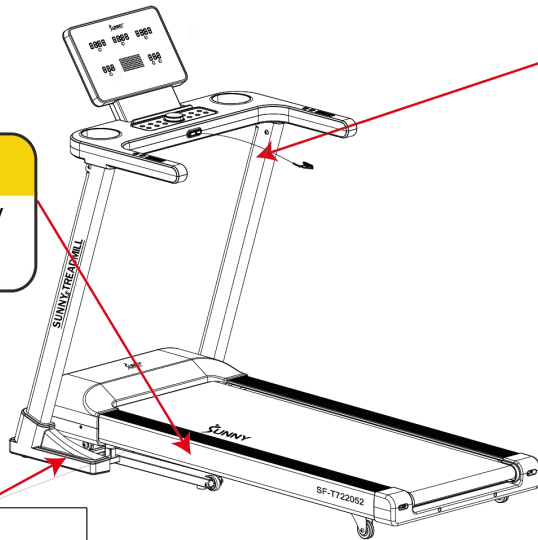

WARNING

Please read all warnings and instructions before using the machine.

Risk of personal injury-Keep children under the age 13 and pets away from the machine.

Remove control box (or key, or safety pin, as applicable) when not in use, and store out of reach of children.

To reduce the risk of electric shock-unplug before cleaning or servicing.

300 LBS/135 KG Weight Capacity

Failure to comply with these warnings could result in serious injury or death.

Make sure all nuts and bolts are securely tightened before each use.

Remove the safety block before assembly.

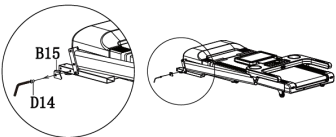

1. Open the carton to remove the equipment and place it on the ground. Do NOT lay the unit on its side!
2. Remove bolt (D14) and safety block (B15) using 5# Allen Wrench.
3. Assemble the treadmill by following the manual instructions.



WARNING

In order to ensure the safety of using the treadmill, please use the power cord with the appropriate socket.



WARNING

In order to ensure the safety of using the treadmill, please use the power cord with the appropriate socket.

CAUTION

Risk of injury to persons: To avoid injury, use extreme caution when stepping onto or off of a moving belt. Read instruction manual before using. To reduce risk of injury from moving parts-unplug before servicing.

Do not pinch the console cable during assembly!

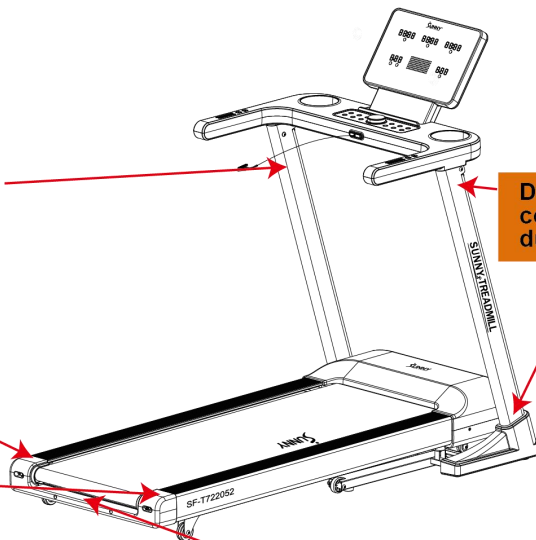

DO NOT PLACE YOUR HAND NEAR OR BETWEEN THE REAR END CAPS & REAR ROLLER!



DO NOT STAND ON THE REAR END CAPS! ALWAYS WEAR SHOES WHEN USING THE EQUIPMENT.

RUNNING BELT ADJUSTMENT

LOOSEN

TIGHTEN

TO ADJUST RUNNING BELT USE ALLEN WRENCH



Assembly Instructions

We value your experience using Sunny Health and Fitness products. For assistance with parts or troubleshooting, please contact us at support@sunnyhealthfitness.com or 1-877-90SUNNY (877-907-8669).

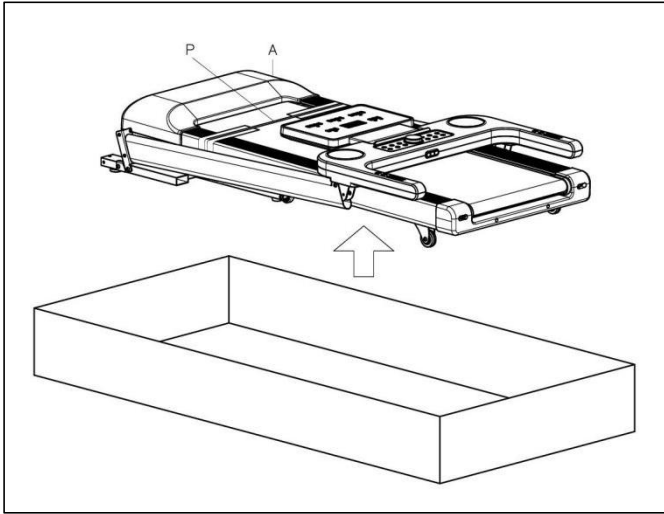

STEP 1:

Open the carton and remove contents. Place the **Main Frame (No. A)** on level ground, ensure that you have a work area that is clean and has adequate space.

Do not cut the **Packing Belt (No. P)** until the assembly is complete!

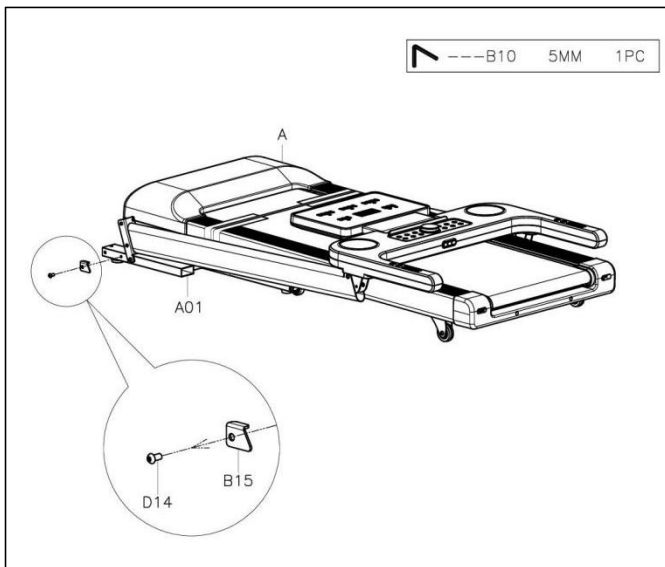

STEP 2:

Loosen the **Bolt (No. D14)** on the **Base Frame (No. A01)** by using **Allen Wrench (No. B10)** and remove the **Safety Block (No. B15)**.

There is no further use for **Bolt (No. D14)**, you can throw it away.

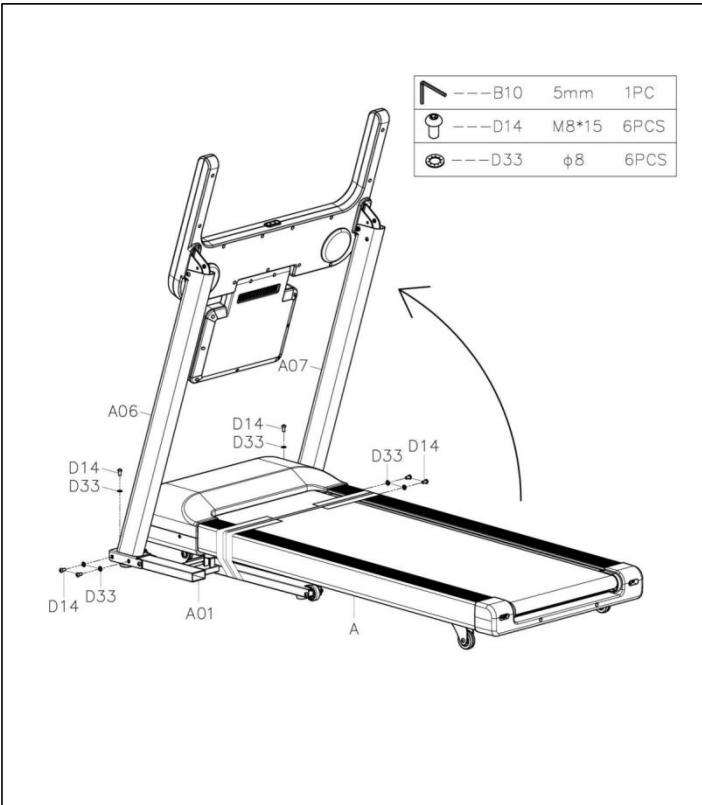

STEP 3:

Lift the **Left & Right Upright Tubes (No. A06 & No. A07)** upward (in the direction specified by the arrows on the diagram to the left).

Support the **Left & Right Upright Tubes (No. A06 & No. A07)** with your hands to prevent them from falling.

Tighten the **Left & Right Upright Tubes (No. A06 & No. A07)** to the **Base Frame (No. A01)** by using **6 Bolts (No. D14)** and **6 Locking Washers (No. D33)**. Secure by using **Allen Wrench (No. B10)**.



STEP 4:

Lift the **Console Top Cover (No. C07)** (in the direction specified by the arrows on the diagram to the left).

NOTE: When lifting, avoid puncturing the wires inside the **Left & Right Upright Tubes (No. A06 & No. A07)** as this will cause damage.

Attach the **Console Top Cover (No. C07)** to the **Left & Right Upright Tubes (No. A06 & No. A07)** by using **4 Bolts (No. D14)** and **4 Locking Washers (No. D33)**. Secure by using **Allen Wrench (No. B10)**.

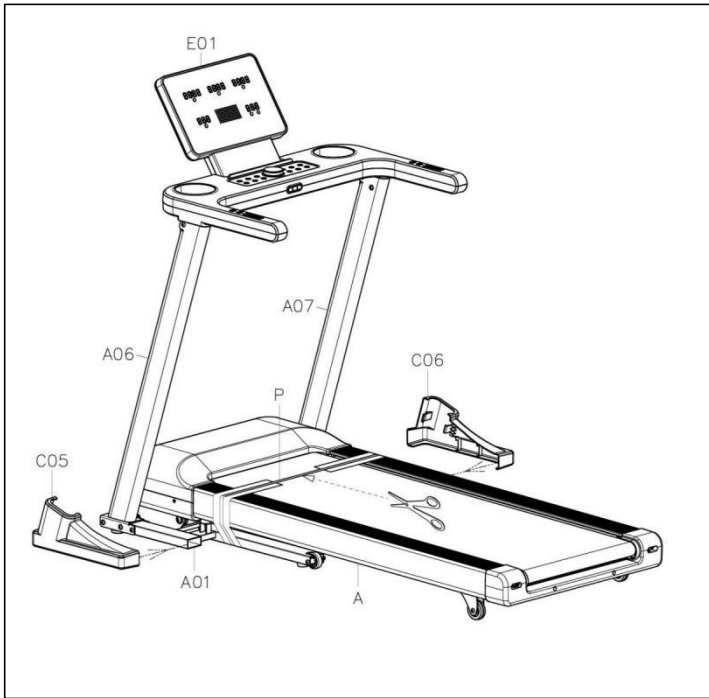

STEP 5:

Adjust the **Console (No. E01)** to the angle you feel comfortable.

Attach the **Left & Right Upright Tube Covers (No. C05 & No. C06)** to the **Left & Right Upright Tubes (No. A06 & No. A07)**.

You may now cut the **Packing Belt (No. P)**.

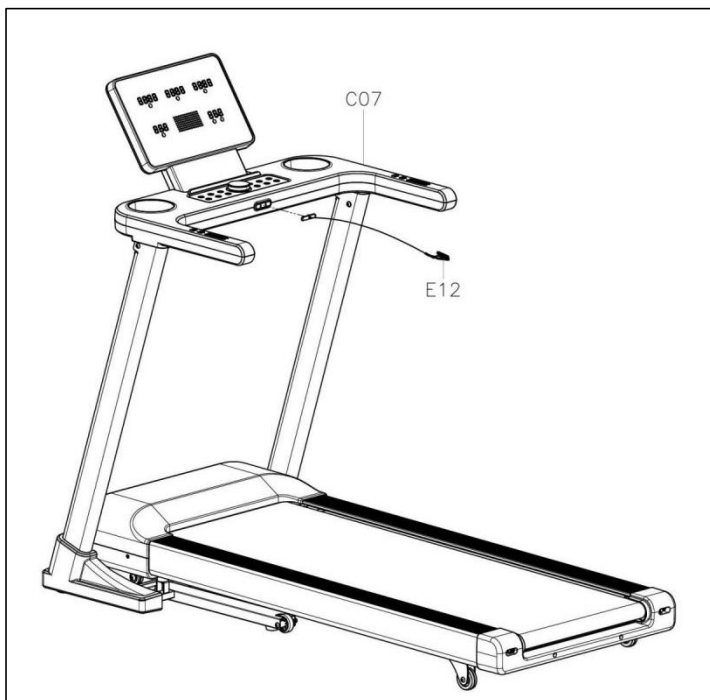

STEP 6:

Insert the pin end of **Safety Key (No. E12)** into the holes on the **Console Top Cover (No. C07)**.

NOTE: Attach the clip end of the **Safety Key (No. E12)** to your clothes before you start your workout.

The assembly is complete!



IMPORTANT NOTE!

You will need to lubricate your treadmill before the first use. See *Page 11*.

Lubricating the Treadmill

IMPORTANT NOTE:

You will need to lubricate your treadmill before the first use.

RUNNING BELTS & TREADMILL LUBRICANT:

Lubricating the **Running Board (No. E23)** and **Running Belt (No. C24)** is essential as the friction affects the life span and operations of the treadmill. Inspect the **Running Belt (No. C24)** and **Running Board (No. E23)** regularly. If you find any wear on the **Running Board (No. E23)**, please contact us at: support@sunnyhealthfitness.com.

WARNING: Always unplug the treadmill from the electrical outlet before cleaning, lubricating, or repairing the unit.

HOW TO LUBRICATE:

1. To apply lubricant, lift one side of the **Running Belt (No. C24)** and apply oil to the middle of the **Running Board (No. E23)**. Next, start the treadmill and place it at the lowest speed setting and allow the oil to spread over the **Running Board (No. E23)**. Repeat this process for the other side.
2. The moving parts should turn freely and quietly. Abnormal moving parts will affect the safety of the equipment. Inspect and tighten bolts regularly.
3. To better maintain the treadmill and prolong its lifespan, it is suggested that maintenance be done on a regular basis.
4. **DO NOT LOOSEN OR MAKE ANY ADJUSTMENTS TO THE RUNNING BELT WHILE APPLYING LUBRICANT.** A loose **Running Belt (No. C24)** will result in the runner sliding off during use, while too tight of a **Running Belt (No. C24)** will negatively affect the motor's performance and create more friction between the roller and **Running Belt (No. C24)**. The most suitable tightness for the **Running Belt (No. C24)** is when it is pulled out 50-75mm from the **Running Board (No. E23)**.

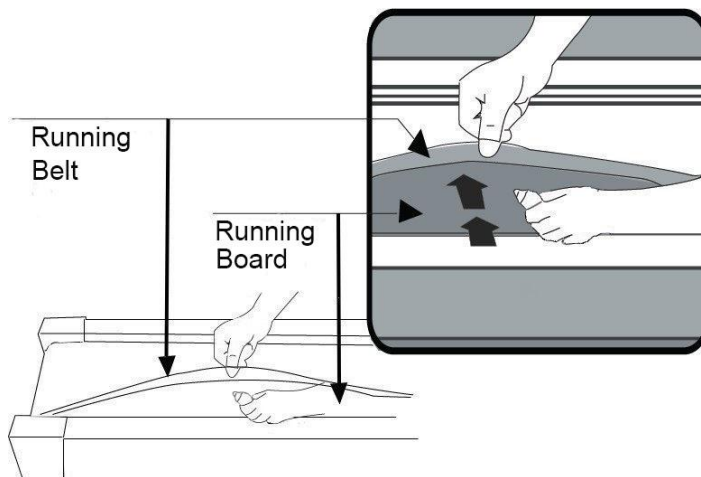

The following timetable is recommended:

Light user (less than 3 hours/ week)	<i>every six months</i>
Medium user (3-5 hours/ week)	<i>every three months</i>
Heavy user (more than 5 hours/ week)	<i>every two months</i>

How to Fold/Unfold the Machine

FOLDING:

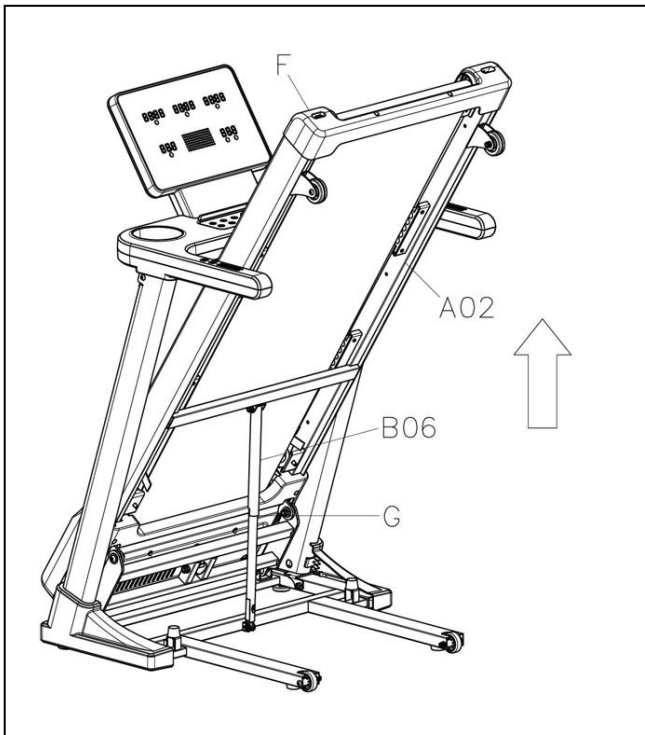

NOTE: Please make sure the incline is at ZERO when folding and unfolding.

Place your hand at position “F” and lift up the **Main Frame (No. A02)** until the **Air Cylinder (No. B06)** “G” locks into the tube.

When the **Air Cylinder (No. B06)** successfully locks into the tube, you will hear a clicking sound.

UNFOLDING:

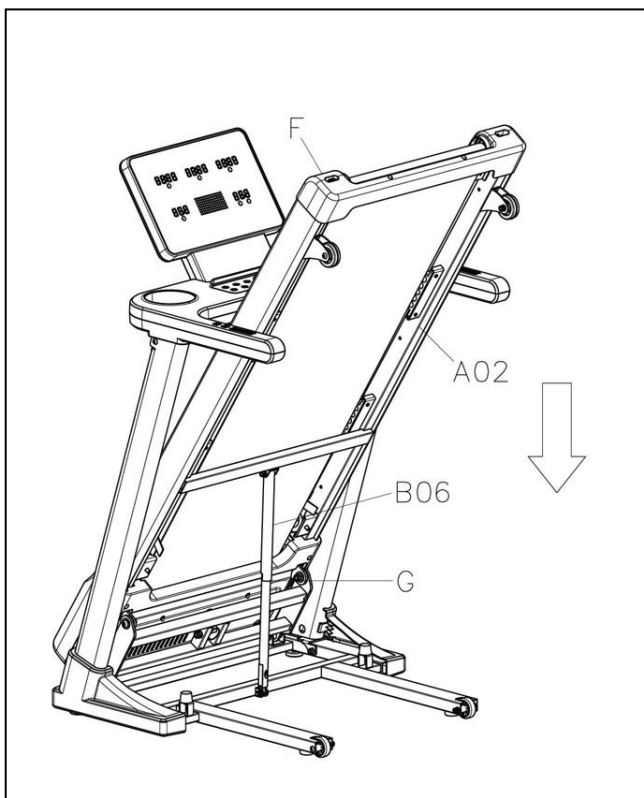

Before lowering the **Main Frame (No. A02)**, ensure that the space directly underneath it is clear of any objects.

Hold the **Main Frame (No. A02)** at position “F” with one hand. Next, using your foot, firmly push against the **Air Cylinder (No. B06)** “G” and press down on the **Main Frame (No. A02)**. Once the **Main Frame (No. A02)** has been pushed down, it will automatically continue to steadily lower itself until it reaches level ground.

(Please keep people and pets away from the treadmill when unfolding.)

How to Move the Machine

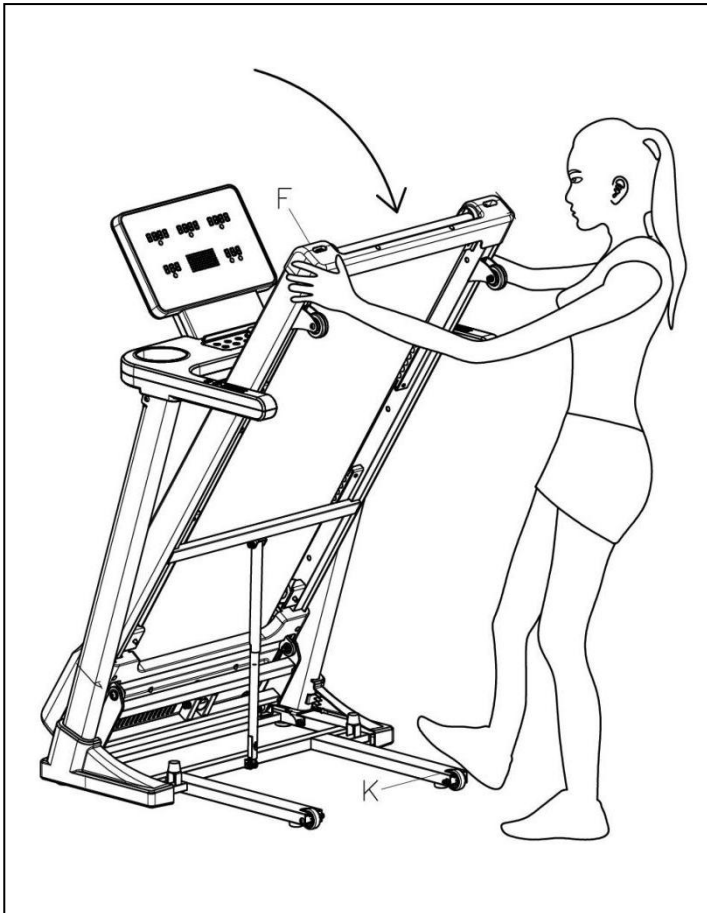

Before attempting to move the treadmill, make sure that it has been properly folded. Unplug the power cord.

To tilt, start by placing one hand at position “F” to support the top end of the treadmill. Next, place one foot at position “K” to hold the bottom end of the treadmill steady. With your foot at “K”, slowly tilt the top of the treadmill downward towards the ground. Once the treadmill reaches a low enough point, the transportation wheels of the treadmill touch the ground.

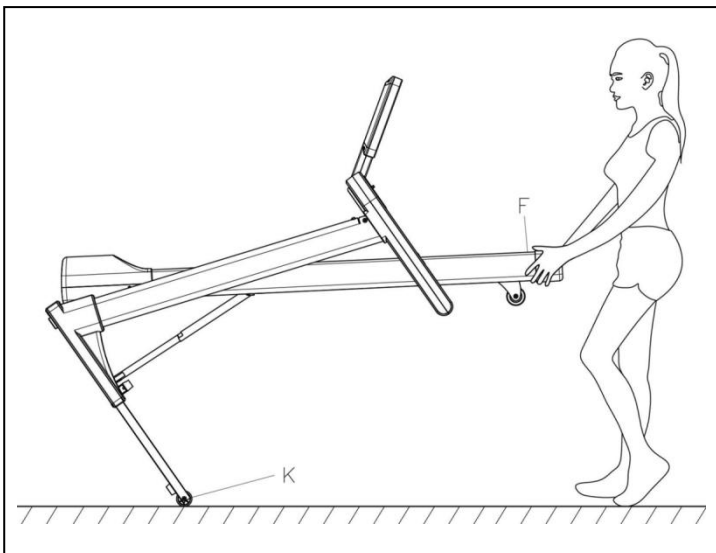

To transport, hold the treadmill at position “F” and tilt until the transportation wheels “K” are able to move on the ground.

Maintenance & Care

General cleaning will help prolong the life and improve performance of your treadmill. Keep the unit clean and maintained by dusting the components on a regular basis. Cleaning two exposed sides of the **Running Belt (No. C24)** will prevent dust from accumulating underneath. Keep your running shoes clean so that dirt from your shoes does not wear out the **Running Board (No. E23)** and **Running Belt (No. C24)**. Clean the surface of the **Running Belt (No. C24)** with a clean damp cloth.

To better maintain the treadmill and prolong its life, it is suggested that the treadmill be powered off for 10 minutes every 2 hours and fully powered off whenever not in use.

CENTERING THE RUNNING BELT:

Place the treadmill on level ground and set it at 6-8KM/H(3-5MPH) to check if the **Running Belt (No. C24)** drifts from the center.

If the **Running Belt (No. C24)** moves to the right, turn the right adjusting bolt $\frac{1}{4}$ turn *clockwise*, then turn the left adjusting bolt $\frac{1}{4}$ turn *counter-clockwise*. If the **Running Belt (No. C24)** does not move, repeat this step until it centers. Refer to Figure A.

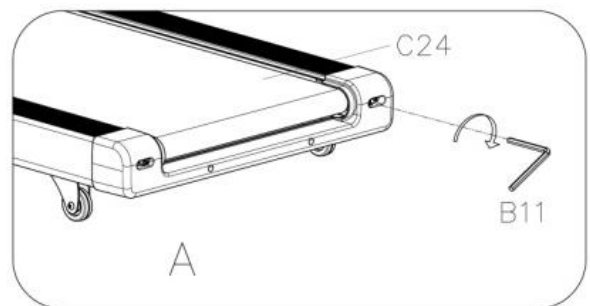

If the **Running Belt (No. C24)** moves to the left, turn the left adjusting bolt $\frac{1}{4}$ turn *clockwise*, then turn the right adjusting bolt $\frac{1}{4}$ turn *counter-clockwise*. If the **Running Belt (No. C24)** does not move, repeat this step until it centers. Refer to Figure B.

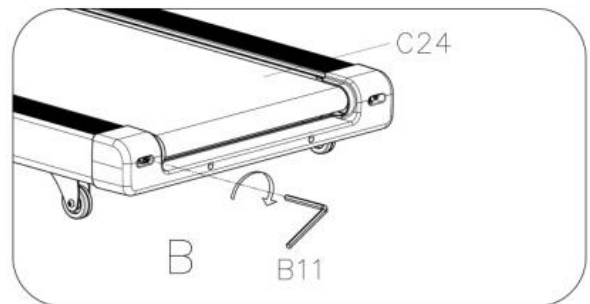

Over time, the **Running Belt (No. C24)** will loosen. To tighten the **Running Belt (No. C24)**, turn the left & right adjusting bolts one full turn *clockwise*, check the tension of the **Running Belt (No. C24)**. Continue this process until **Running Belt (No. C24)** is at the correct tension. Make sure to adjust both sides equally to ensure correct belt alignment. Refer to Figure C.

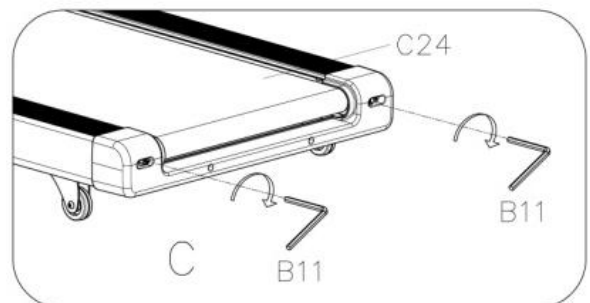

Important Electrical Information

WARNING: This treadmill requires a power source of **10 amps (100-120V)** in order to properly operate. For your safety, as well as the safety of others, please verify that the power source is correct before plugging in the equipment. Any power source above or below this level could cause significant damage to the equipment and/or user.

GROUNDING METHODS:

This product must be grounded. Grounding provides a path of the least resistance for electrical current to reduce the risk of electric shock. The plug must be plugged into an appropriate outlet that is properly installed and grounded in accordance with all local codes and ordinances. Ensure that the product is connected to an outlet which contains the same configuration as the plug. Do not use an adapter for this product.

This product is for use on a nominal 100-120V circuit and has a grounding plug that looks like the plug illustrated in sketch A.

DANGER:

Improper connection of the equipment can result in a risk of electric shock. Check with a qualified electrician or serviceman if you are unsure whether the product has been properly grounded. Do not modify the plug provided with this product. If it will not fit the outlet, have a proper outlet installed by a qualified electrician.

WARNING!

1. **NEVER** use a ground fault circuit interrupt (GFCI) wall outlet with this treadmill. Route the power cord away from all moving parts of the treadmill, including the elevation mechanism and transportation wheels.
2. **NEVER** operate the treadmill using a generator or UPS power supply.
3. **NEVER** remove any cover on the treadmill without first disconnecting power cord.
4. **NEVER** expose the treadmill to rain or moisture. This treadmill is not designed for outdoor use or use in any high humidity environment.

GROUNDING METHOD

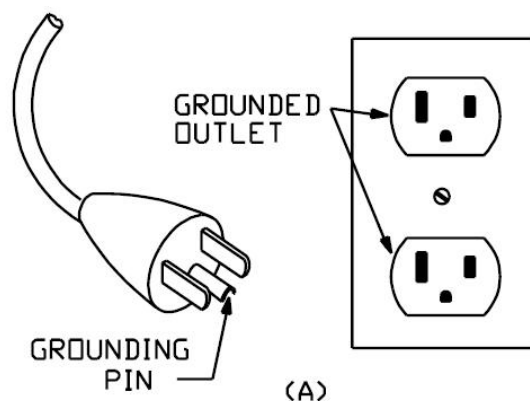

The Display Console

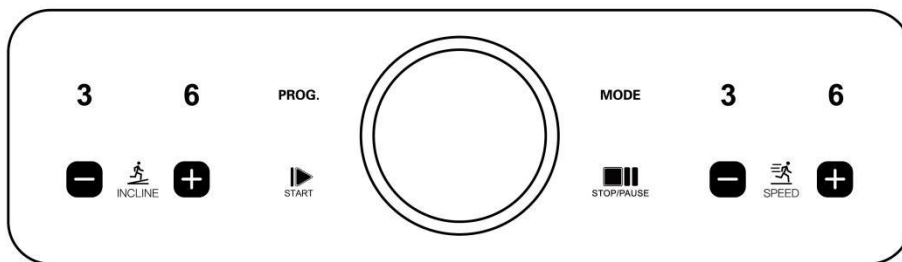
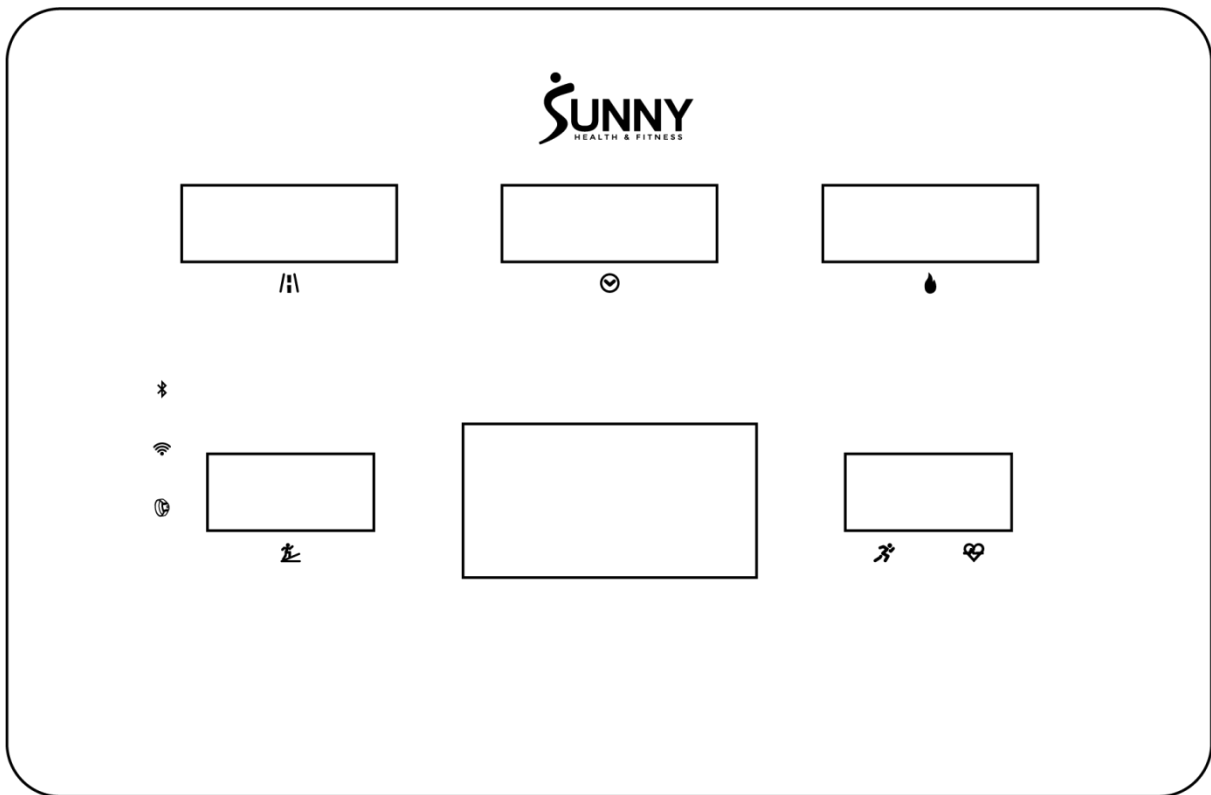

Bluetooth

1. The Bluetooth icon will flash when the console is on or wakes from power saving mode. If no Bluetooth connection is established within 3 minutes, the Bluetooth icon will turn off.
2. The Bluetooth icon will stay on when it is connected.

Wireless Heart Rate

1. The wireless heart rate icon will stay on when the heart rate monitor is connected.
2. The console can be connected to the heart rate monitor at any time except in power saving mode.
3. The wireless heart rate icon will flash when the console is on. If the heart rate monitor is not connected within 3 minutes, the wireless heart rate icon will turn off.

NOTE: The heart rate monitor is not included. Wireless heart rate function works with SunnyFit Heart Rate Monitor HR200.



1. If access point is not configured or fails to be configured, the WIFI indicator light will turn off.
2. After configuring access point, the WIFI indicator light will flash during the connection to the server.
3. The WIFI indicator light will stay on when the server is successfully connected.

NOTE:

1. WIFI function only supports 2.4G frequency, not 5G frequency.
2. Please use SunnyFit APP to configure WIFI and configure it according to the wizard on SunnyFit APP.

Quick Start:

1. Insert the pin end of the **Safety Key (No. E12)** into the holes on the **Console Top Cover (No. C07)**.
2. Press the **START** button or **Switch Knob (No. E06)**, and the system will automatically display a 3 second countdown. Once the countdown reaches zero, the **Running Belt (No. C24)** will start at the initial default speed of 0.6 MPH or 1.0 KM/H.
3. To adjust the speed, you can use the **SPEED +/-** buttons on the **Panel Top Cover (No. C09)** or on handrails, the **QUICK SPEED** buttons 3, 6 MPH(KM/H), or **Switch Knob (No. E06)**.
4. To adjust the incline, you can use the **INCLINE +/-** buttons on the **Panel Top Cover (No. C09)** or on handrails, the **QUICK INCLINE** buttons 3, 6, or **Switch Knob (No. E06)**.

NOTE: The maximum speed on this treadmill is 12.0MPH or 19KM/H.

Window Display:

DISTANCE: Displays the distance traveled (0.0-99.9 MILES/KM). When the distance reaches 99.9 MILES/KM, it will reset to 0.00 and begin counting again from 0.0. When in Countdown Mode, it will count down from the set distance to 0.00. When it reaches 0.00, the treadmill will stop smoothly and display "End" and automatically reset to the initial setting after 5 seconds.

When setting PROGRAMS, Distance window will display P1-P2-...-P24-U1-U2-U3-FAT.

NOTE: The distance and calories will not count when no people walk or run on the treadmill.

TIME: Displays the time elapsed (0:00-99:59 MINS). If the time reaches 99:59, the treadmill will stop smoothly and display "End" then automatically reset to 0:00 after 5 seconds.

When in Countdown Mode, it will count down from the set time to 0:00. When the clock reaches 0:00, the treadmill will stop smoothly and display "End" then automatically reset itself after 5 seconds. Maximum Countdown time is 99:00 minutes: seconds.

CALORIES: Displays the number of calories burned from 0 to 999 KCAL. When the count reaches 999 KCAL, it will reset and start back from 0. When in Countdown Mode, it will count down from the set calories to 0. Once it reaches 0, the treadmill will stop smoothly and display "End", then automatically reset to the initial setting after 5 seconds.

INCLINE: Displays the incline from 0-15 level.

MATRIX: The matrix window will display a 0.25 MILE or 0.4KM running track. Once you finish running the lap, the machine will beep and show the number of laps you've completed. When in Countdown Mode, this window will display "T", "D", "C".

SPEED / PULSE: The speed range is 0.6-12 MPH or 1.0-19KM/H. 0.6MPH or 1.0KM/H is the default running speed.

When the runner holds both hands on the pulse sensors (located on the handles), the system will calculate the runner's heart rate and display it in this window. The pulse range is 50-200 beats/min.

NOTE: This data is for reference only and should not be used for medical purposes.

PROGRAMS	Initial	Default Value	Set Range	Display Range
TIME (MIN: SECOND)	0:00	15:00	5:00-99:00	0:00—99:59
INCLINE	0	0	0-15	0-15
SPEED	0.6MPH 1.0KM/H	0.6MPH 1.0KM/H	0.6-12.0MPH 1.0-19.0KM/H	0.6-12.0MPH 1.0-19.0KM/H
DISTANCE (MILE/KM)	0.00	1.00	0.50-99.9	0.00-99.9
PULSE (BPM)	P	N/A	N/A	50-200
CALORIE (KCAL)	0.0	50	10-999	0.0—999

Console Function Keys:

PROGRAM: Press the PROGRAM button to set your desired interval setting. Programs are displayed as P1-P2---P24-U1-U2-U3 and FAT and the various intervals are shown on the face of the treadmill. P1-P24 are preset programs. U1, U2, U3 are user self-define programs.

MODE: When stopped, press this button to select a Countdown mode.

15:00 MINS is the set Countdown for TIME.

1.0 Mile/KM is the set Countdown for DISTANCE.

50 KCAL is the set Countdown for CALORIES.

When setting each Countdown Mode, you can press the SPEED +/- buttons or INCLINE +/- buttons or **Switch Knob (No. E06)** to increase or decrease from the set data. Press START to start the treadmill.

START: To start the treadmill, insert the pin end of the **Safety Key (No. E12)** into the holes on the **Console Top Cover (No. C07)** and then press the START button. This treadmill requires the **Safety Key (No. E12)** in order to start. 0.6 MPH or 1.0 KM/H is the default start speed.

STOP/PAUSE: When in use, press this button once to PAUSE your workout and the current workout data will still be shown. Press "STOP/PAUSE" button again to terminate your workout session completely and all data will be deleted and reset to the initial setting. in the STOP state, press and hold the "STOP/PAUSE" button for 6 seconds to disconnect the heart rate monitor. To reconnect the heart rate monitor, press and hold the "STOP/PAUSE" button for 6 seconds again.

SPEED +/-: Press the +/- buttons to increase or decrease the speed in increments of 0.1 MPH(KM/H). Pressing and holding either of these buttons will increase or decrease the speed continuously.

3, 6 (QUICK SPEED): These buttons are preset to 3, 6 MPH(KM/H) speeds for convenience.

INCLINE +/-: Press these buttons to adjust incline level. When the treadmill is running, press the +/- buttons to increase or decrease the incline level. Pressing and holding either of these buttons will increase or decrease the incline level continuously.

The incline levels range from 0-15.

3, 6 (QUICK INCLINE): These buttons are preset to 3, 6 inclines for convenience.

SWITCH KNOB: When on Standby Mode, press this knob once to start the treadmill. You can switch incline and speed mode by pressing this knob during running. Once selected, rotate this button to adjust workout parameters of incline or speed. The corresponding function will be displayed in the window of **Switch Knob (No. E06)**.

Switch Knob Function Keys:

SPEED +/-: Turn this knob to increase or decrease the speed in increments of 0.1 MPH(KM/H). Clockwise is increasing and counter-clockwise is decreasing.

INCLINE +/-: Turn this knob to adjust incline level. When the treadmill is running, turn this knob to increase or decrease the incline level. Clockwise is increasing and counter-clockwise is decreasing.

Handrail Function Keys:

SPEED +/- (ON RIGHT HANDRAIL): Press the +/- buttons to increase or decrease the speed in increments of 0.1 MPH. Pressing and holding either of these buttons will increase or decrease the speed continuously.

INCLINE \wedge/\vee (ON LEFT HANDRAIL): Press the \wedge/\vee buttons to increase or decrease the incline in increments of 1. Pressing and holding either of these buttons will increase or decrease the incline continuously.

Lubrication Reminder:

Your treadmill needs lubrication maintenance every 300km (188 Miles). The system will release a beeping sound every 10 seconds and display an "OIL" icon on your display to remind you when it is time. Please read LUBRICATING THE TREADMILL to learn the proper steps to lubricate your treadmill. Apply the lubricant to the middle of the running board on both sides. After application, press and hold the STOP button for 3 seconds to clear the "OIL" reminder.

How To Switch Between Metric and Imperial Mode:

In standby mode, remove the safety key, press SPEED+ and SPEED- buttons at the same time and hold for 5 seconds until you hear a beep. The treadmill should switch between metric and imperial mode. The speed window will show "1.0" in Metric mode and show "0.6" in Imperial mode.

Interval Programs (P1-P24):

Press the PROGRAM button to select an interval setting. Programs are displayed as P1-P24. Select the desired program, and the console will display a countdown starting from 10:00 MINS, press INCLINE +/- buttons or SPEED +/- buttons or use the **Switch Knob (No. E06)** or SPEED +/- buttons or INCLINE \wedge/\vee buttons (ON HANDRAILS) if you wish to increase or decrease the exercise time. Press the START button to start the interval program. The interval program is divided into 10 sections. Each exercise time equals the setting time divided by 10. When the speed enters the next interval, the treadmill will beep, and the speed will be changed according to the set interval. Press INCLINE +/- buttons or SPEED +/- buttons or use the **Switch Knob (No. E06)** or SPEED +/- buttons or INCLINE \wedge/\vee buttons (ON HANDRAILS) to change the INCLINE. After finishing one program, the system will beep and display "End". The machine will gradually come to a stop, then automatically reset to the initial setting after 5 seconds.

TIME PROG.		TIME INTERVAL= setting time/10									
		1	2	3	4	5	6	7	8	9	10
P1	SPEED(MPH)	1.2	2.5	1.8	2.5	1.8	3.1	2.5	1.2	3.1	1.8
	INCLINE	1	2	3	3	1	2	2	3	2	2
P2	SPEED(MPH)	1.2	3.7	4.3	5	1.8	3.7	5	4.3	3.1	1.2
	INCLINE	1	2	3	3	2	2	3	4	2	2
P3	SPEED(MPH)	1.8	5	1.8	5	3.1	5.6	3.1	5.6	7.5	3.7
	INCLINE	1	3	5	7	9	10	8	6	5	2
P4	SPEED(MPH)	5	6.2	6.8	7.5	7.5	6.8	6.2	6.2	5.6	5
	INCLINE	1	2	2	3	1	2	2	2	2	1

P5	SPEED(MPH)	3.7	6.2	7.5	5.6	6.8	5	7.5	4.3	5.6	1.8
	INCLINE	1	2	4	3	2	2	4	5	2	1
P6	SPEED(MPH)	1.2	5	3.7	6.2	6.2	5.6	6.8	5	3.1	1.8
	INCLINE	2	2	3	2	3	4	5	6	5	3
P7	SPEED(MPH)	1.2	3.7	4.3	5.6	4.3	5.6	3.7	3.1	2.5	1.2
	INCLINE	4	5	6	6	9	9	10	12	6	3
P8	SPEED(MPH)	1.2	2.5	3.7	5	4.3	5	5.6	3.7	2.5	1.2
	INCLINE	3	5	4	4	3	4	4	3	3	2
P9	SPEED(MPH)	1.2	2.5	3.1	4.3	3.7	3.1	5	3.7	1.8	1.2
	INCLINE	3	5	3	4	2	3	4	2	3	2
P10	SPEED(MPH)	1.2	1.8	3.1	1.8	1.8	3.1	1.8	3.7	1.8	1.8
	INCLINE	4	4	3	6	7	8	8	6	3	3
P11	SPEED(MPH)	1.2	3.1	5	6.2	3.7	5.6	3.1	1.8	1.2	1.2
	INCLINE	1	3	5	8	10	7	6	3	2	3
P12	SPEED(MPH)	1.2	3.1	3.1	2.5	2.5	3.7	2.5	1.2	1.8	2.5
	INCLINE	3	5	6	7	12	9	11	11	6	3
P13	SPEED(MPH)	1.2	4.3	2.5	4.3	5	5.6	2.5	3.1	1.8	1.2
	INCLINE	5	6	6	4	6	5	8	9	4	2
P14	SPEED(MPH)	1.2	3.7	3.1	2.5	5	3.7	3.1	1.2	1.8	1.8
	INCLINE	5	6	5	8	4	5	5	10	6	3
P15	SPEED(MPH)	1.2	3.7	3.1	2.5	5	4.3	3.1	1.8	1.8	1.2
	INCLINE	3	4	5	6	3	5	5	6	4	3
P16	SPEED(MPH)	1.2	3.1	4.3	3.1	5	3.7	3.1	1.2	2.5	1.2
	INCLINE	1	5	6	8	12	9	10	9	5	3
P17	SPEED(MPH)	1.2	3.1	3.7	4.3	5	5.6	5	3.1	1.8	2.5
	INCLINE	3	5	6	8	6	5	8	7	5	3
P18	SPEED(MPH)	1.2	1.8	3.1	3.7	5	3.7	5.6	3.7	3.1	1.2
	INCLINE	5	7	5	8	6	5	9	10	6	2
P19	SPEED(MPH)	1.8	4.3	3.7	3.1	5.6	4.3	3.7	1.8	3.1	1.2
	INCLINE	3	5	6	8	5	6	5	12	8	3
P20	SPEED(MPH)	1.8	4.3	5.6	6.2	6.8	7.5	6.2	5	3.1	1.2
	INCLINE	2	5	6	7	6	5	8	6	3	2
P21	SPEED(MPH)	1.8	3.7	5	4.3	5.6	6.2	3.1	5	1.8	1.2
	INCLINE	3	6	8	9	9	6	8	10	6	3
P22	SPEED(MPH)	1.8	3.1	5	3.7	5.6	6.2	5	7.5	3.7	1.8
	INCLINE	2	6	8	10	12	10	12	8	5	2
P23	SPEED(MPH)	1.8	3.1	5.6	6.8	7.5	5	3.7	3.1	1.8	1.2
	INCLINE	2	6	8	10	9	7	8	10	6	3
P24	SPEED(MPH)	1.8	5	6.2	6.8	7.5	6.2	6.2	5	3.1	1.8
	INCLINE	3	6	8	9	10	12	9	6	3	2

TIME PROG.		TIME INTERVAL= setting time/10									
		1	2	3	4	5	6	7	8	9	10
P1	SPEED(KM/H)	2	4	3	4	3	5	4	2	5	3
	INCLINE	1	2	3	3	1	2	2	3	2	2

P2	SPEED(KM/H)	2	6	7	8	3	6	8	7	5	2
	INCLINE	1	2	3	3	2	2	3	4	2	2
P3	SPEED(KM/H)	3	8	3	8	5	9	5	9	12	6
	INCLINE	1	3	5	7	9	10	8	6	5	2
P4	SPEED(KM/H)	8	10	11	12	12	11	10	10	9	8
	INCLINE	1	2	2	3	1	2	2	2	2	1
P5	SPEED(KM/H)	6	10	12	9	11	8	12	7	9	3
	INCLINE	1	2	4	3	2	2	4	5	2	1
P6	SPEED(KM/H)	2	8	6	10	10	9	11	8	5	3
	INCLINE	2	2	3	2	3	4	5	6	5	3
P7	SPEED(KM/H)	2	6	7	9	7	9	6	5	4	2
	INCLINE	4	5	6	6	9	9	10	12	6	3
P8	SPEED(KM/H)	2	4	6	8	7	8	9	6	4	2
	INCLINE	3	5	4	4	3	4	4	3	3	2
P9	SPEED(KM/H)	2	4	5	7	6	5	8	6	3	2
	INCLINE	3	5	3	4	2	3	4	2	3	2
P10	SPEED(KM/H)	2	3	5	3	3	5	3	6	3	3
	INCLINE	4	4	3	6	7	8	8	6	3	3
P11	SPEED(KM/H)	2	5	8	10	6	9	5	3	2	2
	INCLINE	1	3	5	8	10	7	6	3	2	3
P12	SPEED(KM/H)	2	5	5	4	4	6	4	2	3	4
	INCLINE	3	5	6	7	12	9	11	11	6	3
P13	SPEED(KM/H)	2	7	4	7	8	9	4	5	3	2
	INCLINE	5	6	6	4	6	5	8	9	4	2
P14	SPEED(KM/H)	2	6	5	4	8	6	5	2	3	3
	INCLINE	5	6	5	8	4	5	5	10	6	3
P15	SPEED(KM/H)	2	6	5	4	8	7	5	3	3	2
	INCLINE	3	4	5	6	3	5	5	6	4	3
P16	SPEED(KM/H)	2	5	7	5	8	6	5	2	4	2
	INCLINE	1	5	6	8	12	9	10	9	5	3
P17	SPEED(KM/H)	2	5	6	7	8	9	8	5	3	4
	INCLINE	3	5	6	8	6	5	8	7	5	3
P18	SPEED(KM/H)	2	3	5	6	8	6	9	6	5	2
	INCLINE	5	7	5	8	6	5	9	10	6	2
P19	SPEED(KM/H)	3	7	6	5	9	7	6	3	5	2
	INCLINE	3	5	6	8	5	6	5	12	8	3
P20	SPEED(KM/H)	3	7	9	10	11	12	10	8	5	2
	INCLINE	2	5	6	7	6	5	8	6	3	2
P21	SPEED(KM/H)	3	6	8	7	9	10	5	8	3	2
	INCLINE	3	6	8	9	9	6	8	10	6	3
P22	SPEED(KM/H)	3	5	8	6	9	10	8	12	6	3
	INCLINE	2	6	8	10	12	10	12	8	5	2
P23	SPEED(KM/H)	3	5	9	11	12	8	6	5	3	2
	INCLINE	2	6	8	10	9	7	8	10	6	3
P24	SPEED(KM/H)	3	8	10	11	12	10	10	8	5	3
	INCLINE	3	6	8	9	10	12	9	6	3	2

Self-Define Program

Besides the 24 preset installed programs, there are 3 user self-define programs: U1, U2, U3.

1. User self-define program setting:

In the initial situation, press “PROG” continuously till U1, U2, U3, and the “TIME” window will show the time 10:00, press SPEED +/- buttons to set the running time; press “MODE” to set program data for the first time interval. Press SPEED +/- buttons, the QUICK SPEED buttons, use the **Switch Knob (No. E06)** or SPEED +/- buttons (ON HANDRAILS) to set the speed. Press INCLINE +/- buttons, the QUICK INCLINE buttons, use the **Switch Knob (No. E06)** or INCLINE \wedge/\vee buttons (ON HANDRAILS) to set the incline. Then press “MODE” button to save the first time interval settings and enter into the second time interval, repeat until all 10 time intervals are set. The data will be kept until the next setting, the data will not be lost when powered off.

2. User self-define program starting:

When the machine is waiting for operation, press the “PROG” button continuously till U1, U2, U3, set the running time then press “START” button to start the machine.

3. User self-define program instruction:

Each program will be divided into 10 time intervals, set the speed in each time interval, then press “START” button to run the machine.

Body Mass Index:

Press the PROGRAM button until the window displays FAT to access Body Mass Index. Press MODE to enter F-1, F-2, F-3, F-4, F-5.

F-1 SEX, F-2 AGE, F-3 HEIGHT, F-4 WEIGHT, F-5 is Body Mass Index

Press SPEED +/- BUTTONS to set F1-F4 (refer to the chart below). Once you have finished setting F1-F4, press MODE. This will enter you into the set up for F-5 (Body Mass Index). To set F-5, grasp the Pulse Sensors located on the handles with both hands and hold them for 3 seconds. The window will display your body mass index. The Body Mass Index is used to test the relation between your height and weight. This is for reference only and not suitable for medical use. The Body Mass Index is suitable for both male and female.

NOTE: General Body Mass Index score is 20-25%

Underweight	Below 19.0
Normal	20.0 - 25.0
Overweight	26.0 - 29.0
Obesity	30.0 - and above

Body Mass Index (BMI) Chart:

F-1	Sex	01 Male	02 Female
F-2	Age	10---99	
F-3	Height	100---240 CM (40---80 INCHES)	
F-4	Weight	20---150 KG (44---330 LBS)	
F-5	BMI	≤19	Underweight
	BMI	=(20---25)	Normal Weight
	BMI	=(26---29)	Overweight
	BMI	≥30	Obesity

Treadmill Functions

Safety Lock Function:

Removing the **Safety Key (No. E12)** from the **Console Top Cover (No. C07)** while the treadmill is running will cause it to stop immediately. Once the treadmill reaches a full stop, the window display of the console will show “- - -” and the speaker will beep 3 times. To start the treadmill again, insert the pin end of the **Safety Key (No. E12)** into the **Console Top Cover (No. C07)** and press the START button.

Power Save Function:

When the treadmill has been inactive for 10 minutes, it will enter Power Saving Mode. While the treadmill is in this mode, the window display of the **Console Top Cover (No. C07)** will be turned off. To turn it back on, press any button.



POWER ON:

Flick the power switch to this symbol to turn on the treadmill.



POWER OFF:

Flick the power switch to this symbol to turn the treadmill off at any time. This includes during exercise.

Safety Note:

We recommend that you maintain a slow speed at the beginning of a session and hold the **Console Top Cover (No. C07)** handrails until you have become familiar with the treadmill.

Exercise Instructions

Getting Started:

Before starting any exercise program, you should consult your physician to determine if you have any medical or physical conditions that could put your health and safety at risk or prevent you from using the equipment properly.

Be aware of your body's signals. Incorrect or excessive exercise can damage your health. Stop exercising immediately if you experience any of the following symptoms: pain, tightness in your chest, irregular heartbeat, shortness of breath, lightheadedness, dizziness, or feelings of nausea. Get to know your treadmill. Before attempting to use the treadmill take some time to stand alongside and familiarize yourself with the controls.

1. Once you get on, you can stand with your feet on the **Side Rails (No. C04)** and stabilize yourself by holding onto the handrails.
2. Next, attach the clip end of the **Safety Key (No. E12)** to your clothes and insert the pin end of the key into the holes on the **Console Top Cover (No. C07)**.
3. Press the START button to start the treadmill.
4. The treadmill will start at the system default setting speed of 0.6MPH/1.0KM/H. When you feel comfortable, you may slowly increase this speed.
5. When you are finished with your exercise, press the STOP button or remove the pin end of the **Safety Key (No. E12)** to stop the treadmill.

USB CHARGING: You can charge your device by the USB port.

APP Connection:

Connect Smart Equipment to SunnyFit App:

1. Scan to download SunnyFit from the app store:



2. Ensure that the Bluetooth function is turned on from your mobile device.
3. If this is your first time using the SunnyFit app, follow the in-app instructions to register for your free SunnyFit account and log in.
4. Begin any workout activity that matches your smart equipment, then follow the onscreen prompts to search for and connect to your smart equipment.
5. When connected, your stats and records will be displayed at the end of your course/session and recorded in your account profile!

APP Troubleshooting:

- If you are having trouble connecting your smart equipment, visit www.sunnyfit.com/guide or scan the QR code below:



- If you require additional support, please contact support@sunnyfit.com.

Troubleshooting

PROBLEM	POSSIBLE CAUSE	SUGGESTED ACTION
Treadmill will not start	Not plugged in.	Plug cord into outlet.
	Safety Key is not inserted.	Insert Safety Key.
Running belt not centered	Running belt tension is not correct on the left or right sides of the running board.	Tighten the left and right adjusting bolts of the rear roller.
Computer not working	Wires from the console and bottom control board are not properly connected.	Check wire from the console to the control board.
	Transformer is damaged.	If the transformer is damaged, contact customer service.
E01/E15: Message failure	Wires from the console and bottom control board are not properly connected.	Check wire connections from the console to the control board. If the wire has been punctured or damaged, you will need to replace it. If the problem is not rectified, you may need to replace the control board.
E03: No hall signal	Hall signal cannot be received by the motor.	Check if the motor hall sensor plug is not inserted properly, or the sensor wire of control board is broken or damaged; If the sensor signal circuit on the control board is abnormal, replace the control board; Replace the motor if the Hall signal inside the motor fails or is damaged.
E04: Incline failure	The incline motor is damaged or the wire for the incline motor is not connected properly or has become damaged	Re-connect or replace the wire for the incline motor. Replace the incline motor with a new one if damaged. Check the control board, replace if damaged. Press incline self-inspection button of the control board once replace a new control board or a new motor.
E06: Current overload protection (Self Protecting System)	The incoming voltage is too low or too high. The control board is damaged.	Press the Overload Protector (No. E16) to restart the treadmill. Restart the treadmill. Check the incoming voltage to ensure it's correct. Check the control board, replace if damaged.
	A moving part of the treadmill is stuck and therefore, the motor is unable to rotate properly.	Inspect moving parts of the treadmill to ensure that they are operating correctly. Check the motor, listen for strange noise and check for a burning smell. Replace the motor if necessary.
E08: Overheat protection	The treadmill is overloaded, the current is too high, the control board is damaged.	Wait for the temperature of control board to drop; Check whether the fan is turning, replace the fan if necessary. Add lubricating oil, replace the control board if necessary.

Exploded Diagram 1

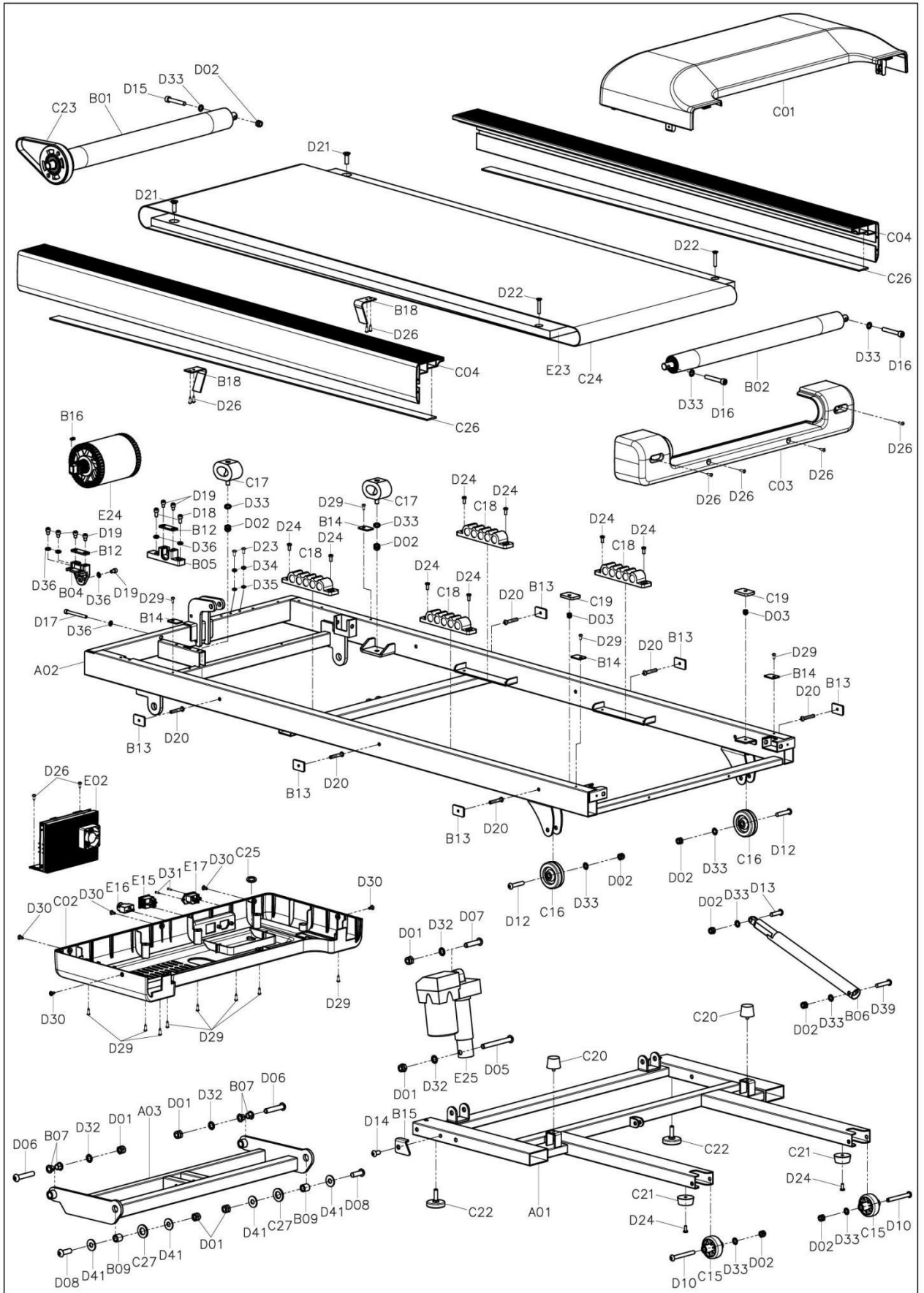

Parts List

No.	Description	Specification	Qty.
A01	Base Frame		1
A02	Main Frame		1
A03	Incline Frame		1
A04	Console Base Bracket		1
A05	Panel Fixed Bracket		1
A06	Left Upright Tube		1
A07	Right Upright Tube		1
B01	Front Roller		1
B02	Rear Roller		1
B03	Hand Pulse Sheet		4
B04	Motor Mount Aluminum L		1
B05	Motor Mount Aluminum R		1
B06	Air Cylinder		1
B07	Incline Frame Bushing		4
B08	Spring		2
B09	Turning Bushing		2
B10	Allen Wrench	5mm	1
B11	Allen Wrench	6mm	1
B12	Motor Fixed Board		2
B13	Side Rail Pressing Plate		6
B14	Front Side Rail Pressing Plate		4
B15	Safety Block		1
B16	Ground Plate		1
B17	Cross Wrench		1
B18	Guide Hook		2
C01	Motor Top Cover		1
C02	Motor Bottom Cover		1
C03	Rear Cover		1
C04	Side Rail		2
C05	Left Upright Tube Cover		1
C06	Right Upright Tube Cover		1
C07	Console Top Cover		1
C08	Console Bottom Cover		1
C09	Panel Top Cover		1
C10	Panel Bottom Cover		1
C11	Safety Key Socket		1
C12	Button +		1
C13	Button -		1
C14	Button1		2
C15	Transportation Wheel		2
C16	Adjustable Wheel		2
C17	Cushion		2
C18	Middle Cushion		4

No.	Description	Specification	Qty.
C19	Rubber Cushion		2
C20	Tapered Cushion		2
C21	Foot Pad		2
C22	Adjustable Foot pad		2
C23	Motor Belt		1
C24	Running Belt		1
C25	Ring Protection Wire		2
C26	EVA Pad		2
C27	Plastic Gasket	Φ30*3	2
C28	EVA Pad	30*30*1	2
D01	Nut	M10	6
D02	Nut	M8	9
D03	Nut	M6	2
D04	Bolt	M10*95 L25	2
D05	Bolt	M10*90 L20	1
D06	Bolt	M10*55 L15	2
D07	Bolt	M10*45 L15	1
D08	Bolt	M10*30 L15	2
D09	Bolt	M8*80 L15	2
D10	Bolt	M8*70 L20	2
D11	Bolt	M8*50 L15	2
D12	Bolt	M8*40 L20	2
D13	Bolt	M8*30 L15	1
D14	Bolt	M8*15	11
D15	Bolt	M8*60	1
D16	Bolt	M8*55	2
D17	Bolt	M6*60	1
D18	Bolt	M6*20	2
D19	Bolt	M6*12	7
D20	Bolt	M6*38	6
D21	Bolt	M8*25	2
D22	Bolt	M6*32	2
D23	Bolt	M5*12	2
D24	Bolt	M5*12 (head with pad)	10
D25	Screw	ST4.2*20	7
D26	Pan Head Tapping Screw	ST4.2*12	50
D27	Pan Head Tapping Screw	ST2.9*8	14
D28	Screw	ST2.9*6	15
D29	Screw	ST4.2*12 (head with pad)	12
D30	Countersunk Head Screw	ST4.2*12	5
D31	Countersunk Head Screw	ST2.9*8	2
D32	Locking Washer	Φ10	4
D33	Locking Washer	Φ8	21

No.	Description	Specification	Qty.
D34	Locking Washer	Φ5	2
D35	Spring Washer	Φ5	2
D36	Flat Washer	Φ6	6
D37	Big Washer	Φ10	8
D38	Screw	ST2.0*6	4
D39	Bolt	M8*42 L20	1
D40	Nut	M10	2
D41	Big Washer	Φ10	4
E01	Console		1
E02	Control Board		1
E03	Upper Signal Wire		1
E04	Lower Signal Wire		1
E05	Handpulse Top Signal Wire		1
E06	Switch Knob		1
E07	Button Board Top Signal Wire		1
E08	Handpulse Bottom Signal Wire		2
E09	Quick Incline Board		1
E10	Quick Speed Board		1
E11	Safety Key Connecting Wire		1
E12	Safety Key		1
E13	Magnetic Ring		1
E14	Magnetic Core		1
E15	Square Switch		1

No.	Description	Specification	Qty.
E16	Overload Protector		1
E17	Power Socket		1
E18	Power Wire		1
E19	Grounding Wire		1
E20	AC Single Line	Brown 200	1
E21	AC Single Line	Brown 350	2
E22	AC Single Line	Blue 350	2
E23	Running Board		1
E24	Brushless Motor		1
E25	Incline Motor		1
E26	Left Button Board		1
E27	Right Button Board		1
E28	Button Board Wire		1
E29	Knob Connecting Wire		1
E30	Magnetic Ring 3		1
F01	Filter		1
F02	AC Single Line	Brown	1
F03	AC Single Line	Blue	1
F04	Grounding Wire		1
F05	Pan Head Self-Drilling Tapping Screw	ST4.2*12	2
H01	USB Module		1
H02	USB Connecting Wire		1
H03	Screw	ST2.9*8	3

Register

Register your product and verify warranty terms:

Sunnyhealthfitness.com/warranty



Download

Track your fitness progress & join **FREE** workout courses!

Download SunnyFit App today!



Follow

Find us on social media



Contact

Get in touch with us for any questions

 1-877-90SUNNY (877-907-8669)

 support@sunnyhealthfitness.com