

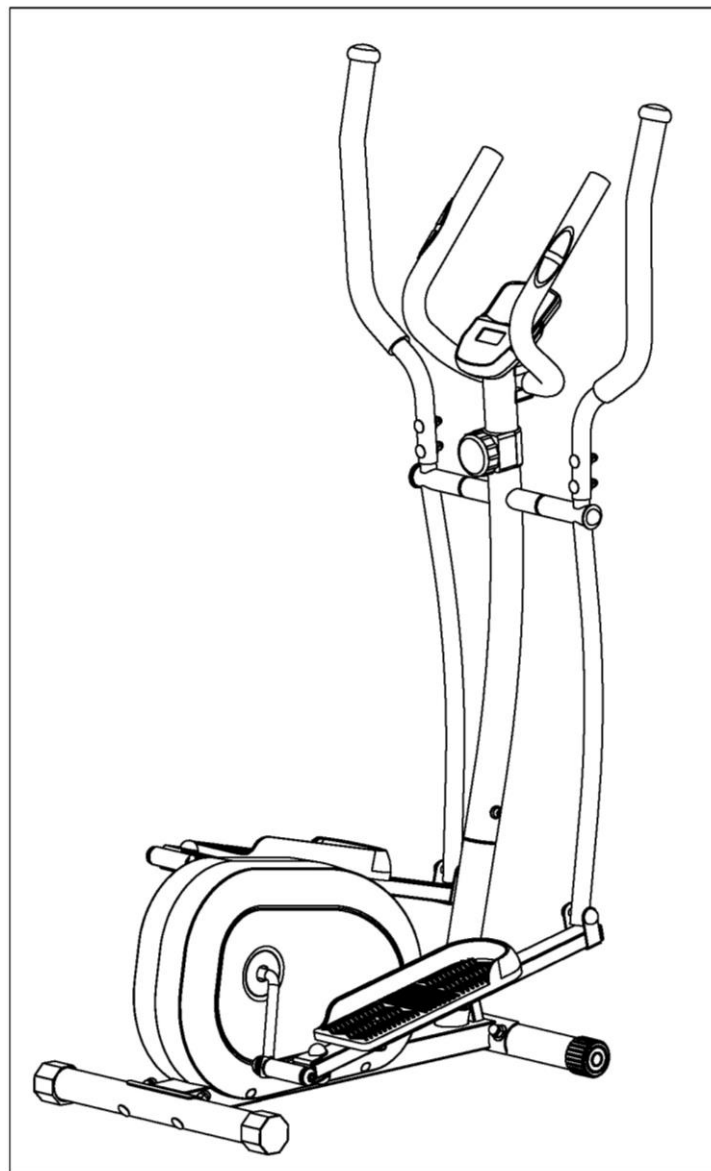

SMART MAGNETIC ELLIPTICAL

SF-E905 SMART

USER MANUAL



IMPORTANT! Please retain owner's manual for maintenance and adjustment instructions. Your satisfaction is very important to us, **PLEASE DO NOT RETURN UNTIL YOU HAVE CONTACTED US:** support@sunnyhealthfitness.com or 1-877-90SUNNY (877-907-8669).



WWW.SUNNYHEALTHFITNESS.COM

IMPORTANT SAFETY INFORMATION

We thank you for choosing our product. To ensure your safety and health, please use this equipment correctly. It is important to read this entire manual before assembling and using the equipment. Safe and effective use can only be achieved if the equipment is assembled, maintained, and used properly. It is your responsibility to ensure that all users of the equipment are informed of all warnings and precautions.

1. Before starting any exercise program, you should consult your physician to determine if you have any medical or physical conditions that could put your health and safety at risk, or prevent you from using the equipment properly. Your physician's advice is essential if you are taking medication that affects your heart rate, blood pressure or cholesterol level.
2. Be aware of your body's signals. Incorrect or excessive exercise can damage your health. Stop exercising if you experience any of the following symptoms: pain, tightness in your chest, irregular heartbeat, shortness of breath, lightheadedness, dizziness, or feelings of nausea. If you do experience any of these conditions, you should consult your physician before continuing with your exercise program.
3. Keep children and pets away from the equipment. The equipment is designed for adult use only.
4. Use the equipment on a solid, flat level surface with a protective cover for your floor or carpet. To ensure safety, the equipment should have at least 2 feet (60 cm) of free space all around it.
5. Ensure that all nuts and bolts are securely tightened before using the equipment. The safety of the equipment can only be maintained if it is regularly examined for damage and/or wear and tear.
6. Always use the equipment as indicated. If you find any defective components while assembling or checking the equipment, or if you hear any unusual noises coming from the equipment during exercise, discontinue use of the equipment immediately and do not use until the problem has been rectified.
7. Wear suitable clothing while using the equipment. Avoid wearing loose clothing that may become entangled in the equipment.
8. Do not place fingers or objects into the moving parts of the equipment.
9. The maximum weight capacity of this unit is 220 lbs (100 kgs).
10. The equipment is not suitable for therapeutic use.
11. To avoid bodily injury and/or damage to the product or property, proper lifting and moving is required.
12. Your product is intended for use in cool, dry conditions. You should avoid storing in extreme cold, hot, or damp areas as this may lead to corrosion and other related problems.
13. This equipment is designed for indoor and home use only. It is not intended for commercial use!

PRE-ASSEMBLY CHECK LIST

Before you start to assemble, please make sure all parts are included.

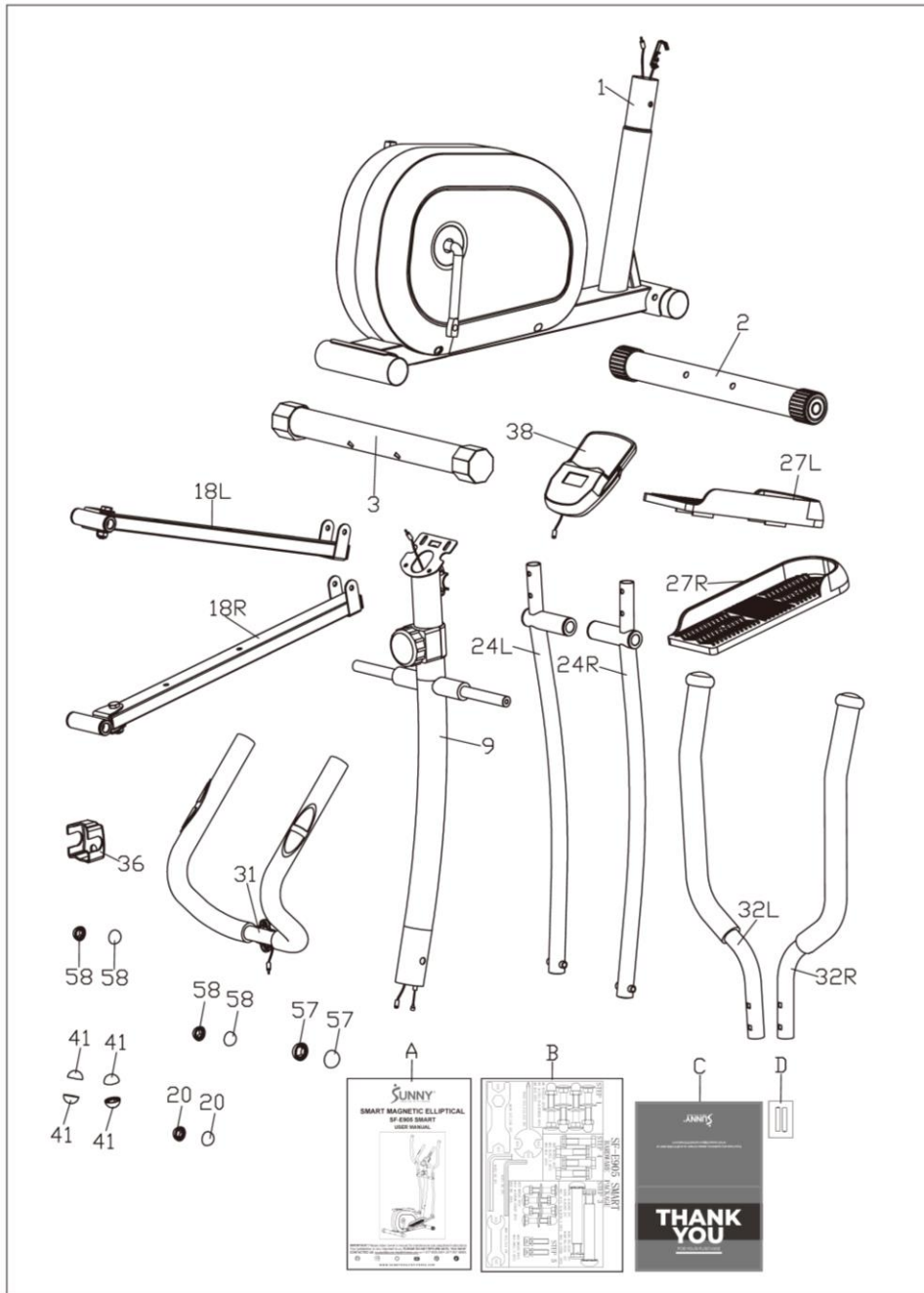

No.	Description	Spec.	Qty.
1	Main Frame		1
2	Front Stabilizer		1
3	Rear Stabilizer		1
9	Handlebar Post		1
18L	Left Pedal Support Tube		1
18R	Right Pedal Support Tube		1
20	Nut Cap	S13	2
24L	Left Swing Bar		1
24R	Right Swing Bar		1
27L	Left Pedal		1
27R	Right Pedal		1
31	Armrest		1

No.	Description	Spec.	Qty.
32L	Left Handlebar		1
32R	Right Handlebar		1
36	Decorative Cover		1
38	Meter	BJHT060	1
41	Nut Cap	S17	4
57	Nut Cap	S19	2
58	Nut Cap	S14	4
A	Manual		1
B	Hardware Package		1
C	Thank You Card		1
D	Battery	AAA	2

HARDWARE PACKAGE

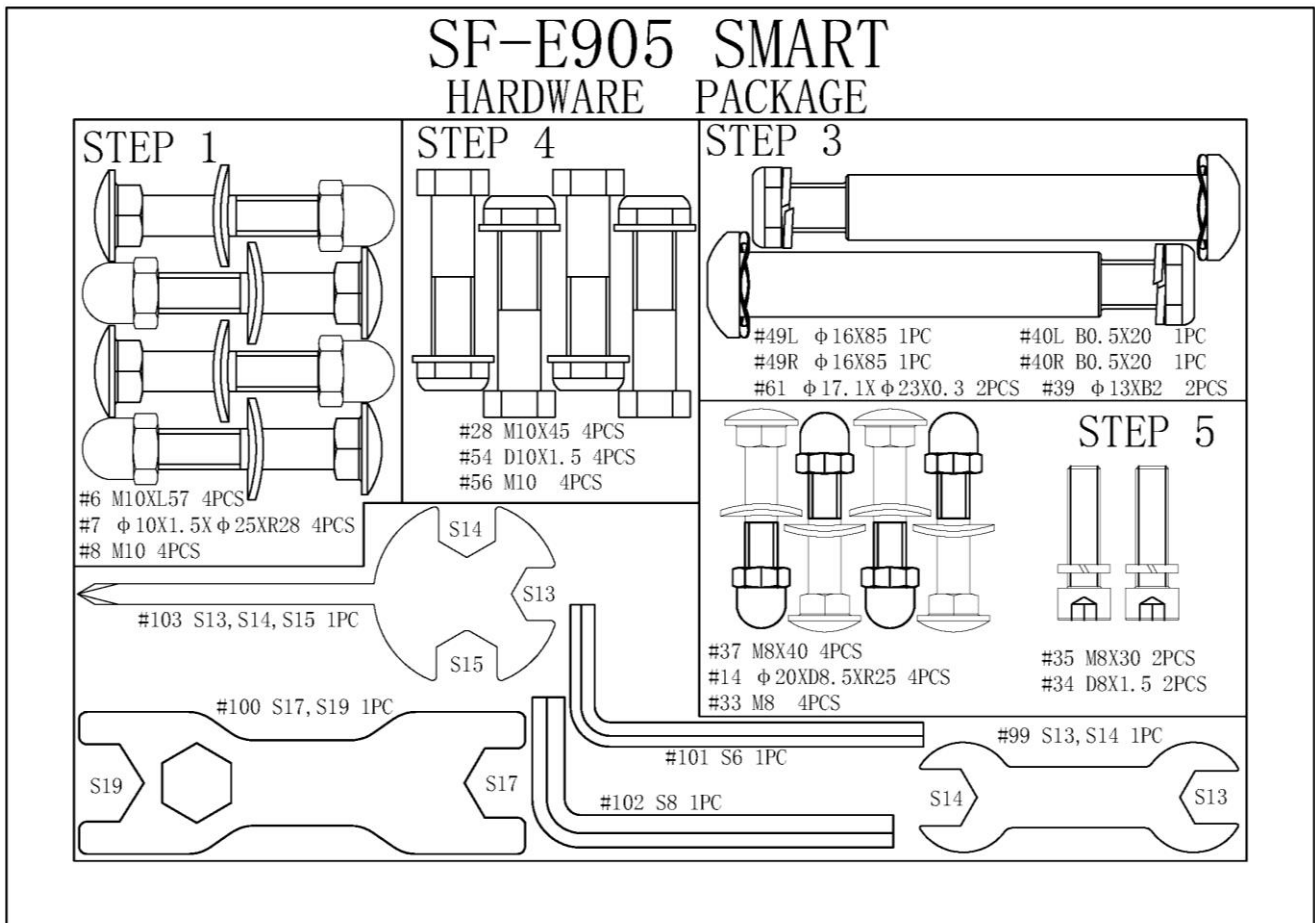

Ordering Replacement Parts (U.S. and Canadian Customers only)

Please provide the following information in order for us to accurately identify the part(s) needed:

- ✓ The model number (found on cover of manual)
- ✓ The product name (found on cover of manual)
- ✓ The part number found on the "EXPLODED DIAGRAM" (page 13) and "PARTS LIST" (pages 14~15)

Please contact us at support@sunnyhealthfitness.com or 1-877-90SUNNY (877-907-8669).

ASSEMBLY INSTRUCTIONS

We value your experience using Sunny Health and Fitness products. For assistance with parts or troubleshooting, please contact us at support@sunnyhealthfitness.com or 1-877-90SUNNY (877-907-8669).

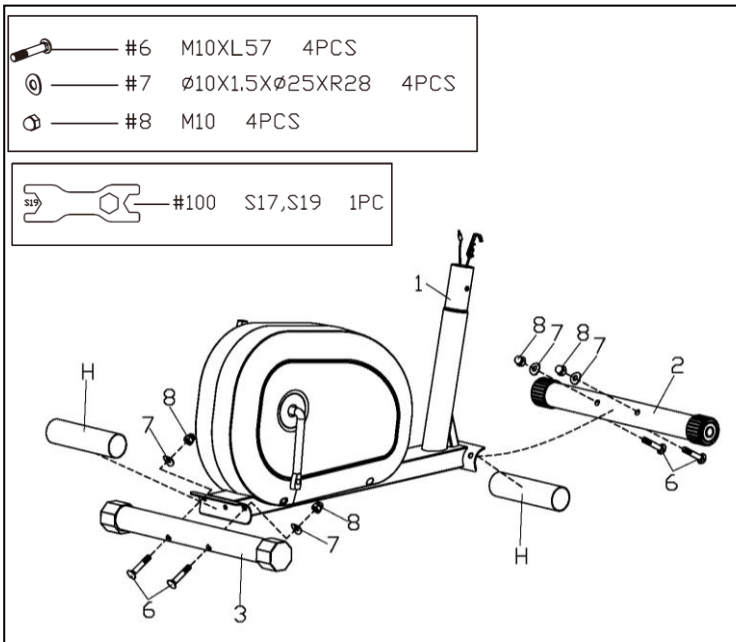

STEP 1:

Remove 2 **Plastic Tubes (No. H)** from the **Main Frame (No. 1)**.

Attach the **Front Stabilizer (No. 2)** and **Rear Stabilizer (No. 3)** onto the **Main Frame (No. 1)**, with 4 **Carriage Bolts (No. 6)**, 4 **Arc Washers (No. 7)** and 4 **Domed Nuts (No. 8)**. Tighten and secure with **Spanner (No. 100)**.

NOTE: Ensure all bolts and washers are in place and partially threaded in before completely tightening them.

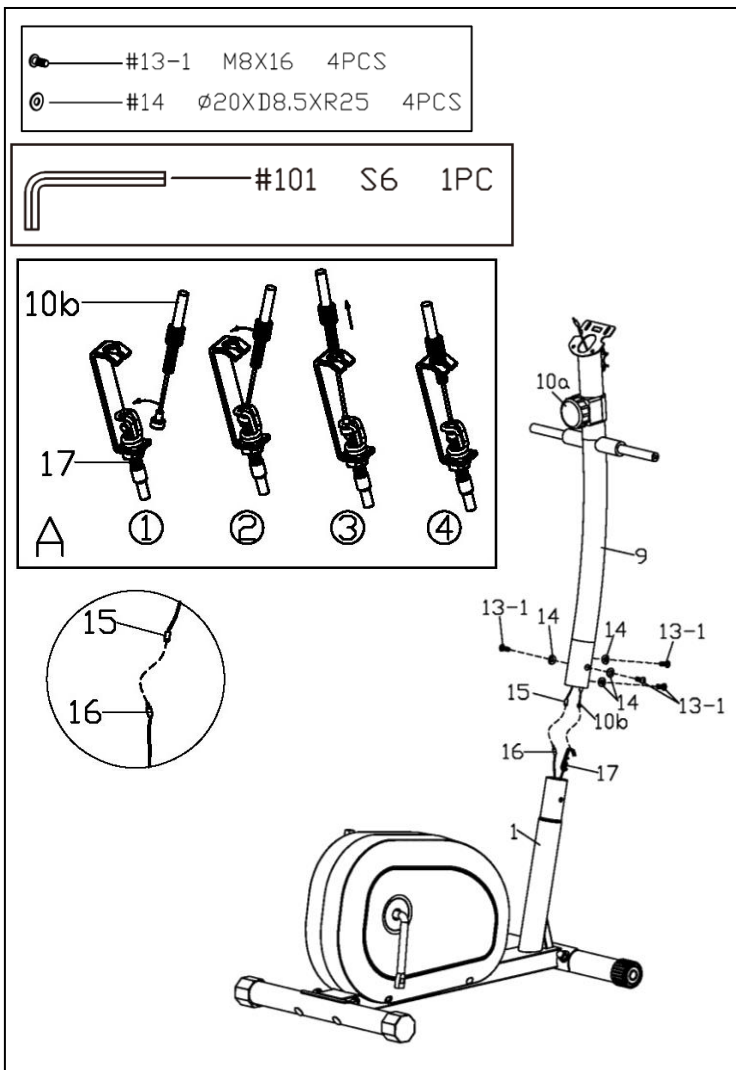

STEP 2:

Connect the **Lower Sensor Wire (No. 16)** with the **Upper Sensor Wire (No. 15)**, and then connect **Tension Hook (No. 17)** with **Tension Cable (No. 10b)** as shown in Diagram A.

NOTE: Make sure the **Tension Controller (No. 10a)** is at the lowest level before you connect the **Tension Cable (No. 10b)**. This ensures the wires are at their longest point. We recommend the assistance of a second person to help hold the **Handlebar Post (No. 9)**. This will make attaching the **Tension Hook (No. 17)** to the **Tension Cable (No. 10b)** easier.

Remove 4 **Allen Bolts (No. 13-1)** and 4 **Arc Washers (No. 14)** from the **Main Frame (No. 1)** with **Allen Wrench (No. 101)**. Insert the **Handlebar Post (No. 9)** into the post of the **Main Frame (No. 1)** secure with the 4 **Allen Bolts (No. 13-1)** and 4 **Arc Washers (No. 14)** that were just removed. Tighten and secure with **Allen Wrench (No. 101)**.

NOTE: Ensure that all bolts and washers are in place and partially threaded in before completely tightening them.

We value your experience using Sunny Health and Fitness products. For assistance with parts or troubleshooting, please contact us at support@sunnyhealthfitness.com or 1-877-90SUNNY (877-907-8669).

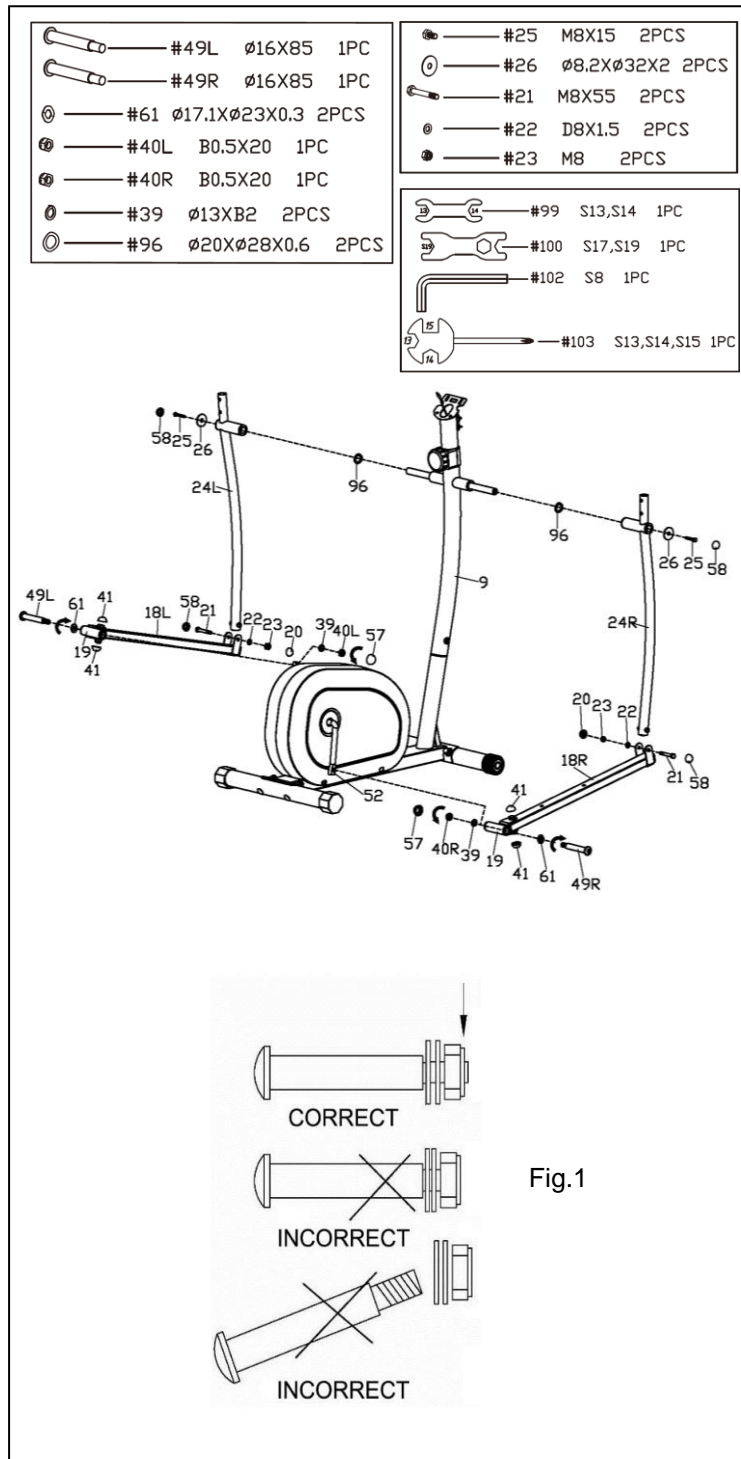

STEP 3:

Remove 2 **Wave Washers (No. 96)**, 2 **Hex Bolts (No. 25)** and 2 **Flat Washers (No. 26)** from the long axle of the **Handlebar Post (No. 9)** with **Spanner (No. 103)**.

Attach 2 **Wave Washers (No. 96)** to the two sides of the long axle on the **Handlebar Post (No. 9)**. Then attach the **Left & Right Swing Bars (No. 24L & No. 24R)** to the two sides of the long axle on the **Handlebar Post (No. 9)** with 2 **Hex Bolts (No. 25)** and 2 **Flat Washers (No. 26)** that were just removed. Tighten and secure with **Spanner (No. 103)**.

NOTE: Please do not fully tighten at this time.

Attach the **Connecting Joint (No. 19)** on the **Left Pedal Support Tube (No. 18L)** to the left side of **Crank Arm (No. 52)** with 1 **Left Hinge Bolt (No. 49L)**, 1 **Wave Washer (No. 61)**. Turn the **Left Hinge Bolt (No. 49L)** *counter-clockwise* as tightly as you can with your hand. Secure by tightening 1 **Spring Washer (No. 39)** and 1 **BLACK color Left Nylon Nut (No. 40L)** *clockwise*. Then use **Allen Wrench (No. 102)** and **Spanner (No. 100)** to tighten securely.

Attach the **Connecting Joint (No. 19)** on the **Right Pedal Support Tube (No. 18R)** to the right side of **Crank Arm (No. 52)** with 1 **Right Hinge Bolt (No. 49R)**, 1 **Wave Washer (No. 61)**. Turn the **Right Hinge Bolt (No. 49R)** *clockwise* as tightly as you can with your hand. Secure by tightening 1 **Spring Washer (No. 39)** and 1 **WHITE color Right Nylon Nut (No. 40R)** *counter-clockwise*. Then use **Allen Wrench (No. 102)** and **Spanner (No. 100)** to tighten securely.

NOTE: Please do not fully tighten at this time. Please attach the **Left & Right Hinge Bolts (No. 49L & No. 49R)** correctly as shown in Fig.1.

Remove 2 **Hex Bolts (No. 21)**, 2 **Flat Washers (No. 22)** and 2 **Nylon Nuts (No. 23)** from **Left & Right Pedal Support Tubes (No. 18L & No. 18R)** using **Spanner (No. 103)** and **Spanner (No. 99)**. Then attach the **Left & Right Swing Bars (No. 24L & No. 24R)** to the **Left & Right Pedal Support Tubes (No. 18L & No. 18R)** with 2 **Hex Bolts (No. 21)**, 2 **Flat Washers (No. 22)** and 2 **Nylon Nuts (No. 23)** that were just removed. Tighten and secure with **Spanner (No. 103)** and **Spanner (No. 99)**.

NOTE: If fail to screw in **Hex Bolts (No. 21)**, please move the **Crank Arm (No. 52)** to a different angle and retry it.

Tighten 2 **Hex Bolts (No. 25)** and **Left & Right Nylon Nuts (No. 40L & No. 40R)** tightly now. Then cover with the 12 **Nut Caps (No. 20 & No. 58 & No. 57 & No. 41)**.

We value your experience using Sunny Health and Fitness products. For assistance with parts or troubleshooting, please contact us at support@sunnyhealthfitness.com or 1-877-90SUNNY (877-907-8669).

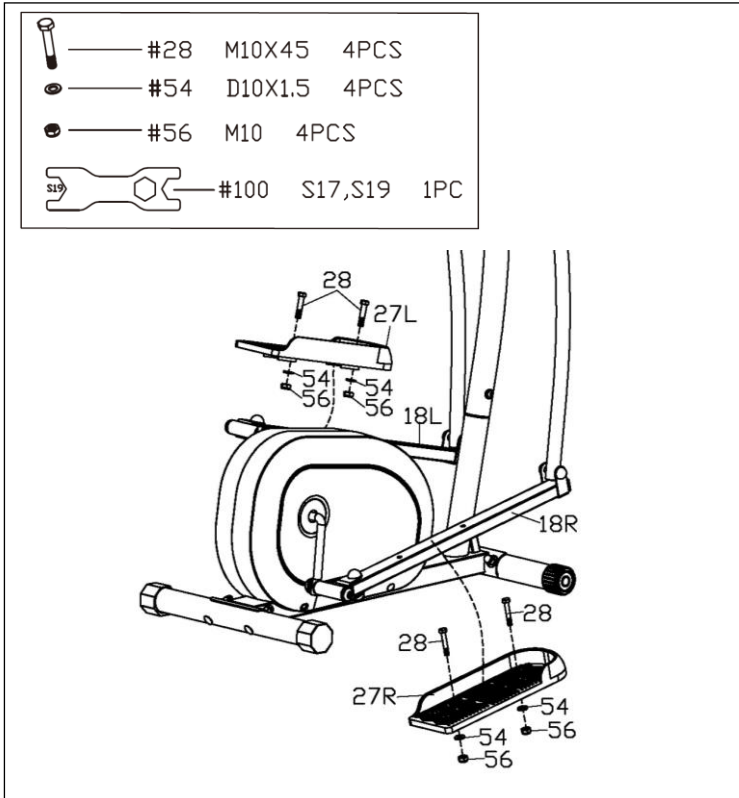

STEP 4:

Secure the **Left & Right Pedals (No. 27L & No. 27R)** to the **Left & Right Pedal Support Tubes (No. 18L & No. 18R)** respectively using 4 **Hex Bolts (No. 28)**, 4 **Flat Washers (No. 54)** and 4 **Nylon Nuts (No. 56)**. Tighten and secure with **Spanner (No. 100)**.

NOTE: Both pedals are labeled L and R; L for LEFT and R for RIGHT.

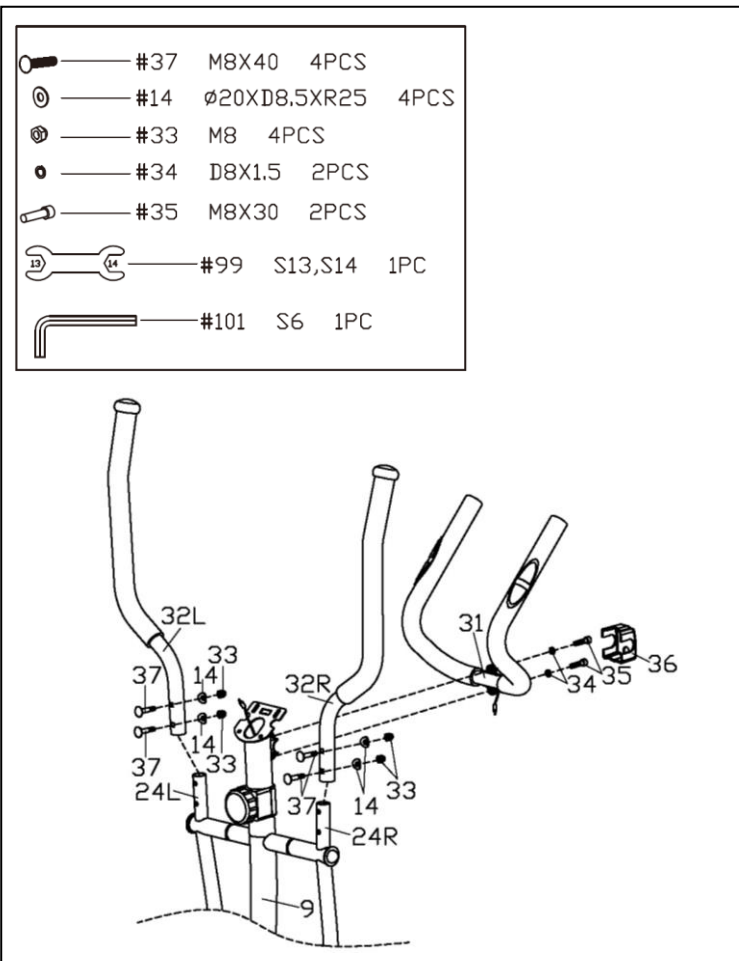

STEP 5:

Attach **Armrest (No. 31)** to the **Handlebar Post (No. 9)**. Secure with 2 **Spring Washers (No. 34)** and 2 **Hex Bolts (No. 35)** using **Allen Wrench (No. 101)**. Finally attach the **Decorative Cover (No. 36)** onto the **Armrest (No. 31)**.

Attach the **Left & Right Handlebars (No. 32L & No. 32R)** onto the **Left & Right Swing Bars (No. 24L & No. 24R)** with 4 **Carriage Bolts (No. 37)**, 4 **Arc Washers (No. 14)** and 4 **Domed Nuts (No. 33)**. Tighten and secure with **Spanner (No. 99)**.

NOTE: If the **Left & Right Handlebars (No. 32L & No. 32R)** rubs against the **Armrest (No. 31)** during the workout, please recheck if the **Left & Right Handlebars (No. 32L & No. 32R)** is assembled to **Left & Right Swing Bars (No. 24L & No. 24R)** according to the label marked with L or R.

We value your experience using Sunny Health and Fitness products. For assistance with parts or troubleshooting, please contact us at support@sunnyhealthfitness.com or 1-877-90SUNNY (877-907-8669).

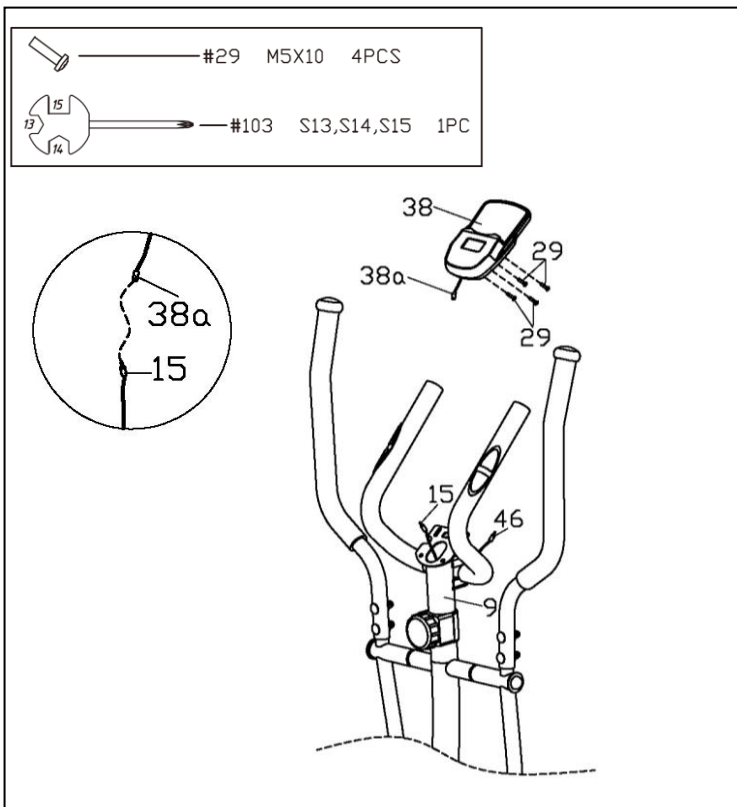

STEP 6:

Remove 4 **Phillips Screws (No. 29)** from the **Meter (No. 38)** with **Spanner (No. 103)**.

Plug the **Pulse Sensor Wire (No. 46)** to the jack on the back of the **Meter (No. 38)**. Then connect the **Upper Sensor Wire (No. 15)** to the **Meter Wire (No. 38a)**.

Attach the **Meter (No. 38)** to the bracket of the **Handlebar Post (No. 9)** using 4 **Phillips Screws (No. 29)** that were just removed. Tighten and secure with **Spanner (No. 103)**.

NOTE: To avoid damaging the wires, please push them into the **Handlebar Post (No. 9)** before securing the **Meter (No. 38)** onto the bracket.

THE ASSEMBLY IS COMPLETE!

TROUBLESHOOTING

1. If you find there is no difference between tension level 1 to level 8, please check the connection of the tension cable. Please see Diagram A under STEP 2.

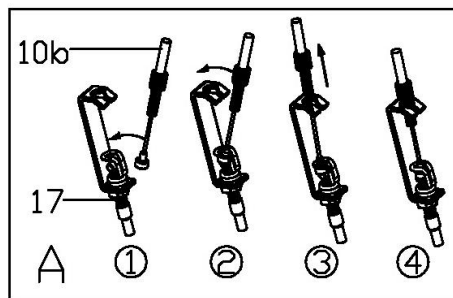

2. If the meter does not show numbers correctly, please check the batteries. If the meter does not count the speed and time, please check the connections of **Upper Sensor Wire (No. 15)** to the **Meter Wire (No. 38a)**, and **Upper Sensor Wire (No. 15)** to **Lower Sensor Wire (No. 16)**.
3. If you have difficulty in putting **Left & Right Hinge Bolts (No. 49L & No. 49R)** into the **Crank Arm (No. 52)**, or putting **Hex Bolts (No. 21)** into **Left & Right Pedal Support Tubes (No. 18L & No. 18R)**, please try moving the **Crank Arm (No. 52)** to a different angle. *Keep in mind the **Left Hinge Bolt (No. 49L)** has reversed threading and must be installed by turning counter-clockwise.
4. If you hear any noise when using the machine, please check if **Left & Right Hinge Bolts (No. 49L & No. 49R)**, **Hex Bolts (No. 21)**, **Hex Bolts (No. 25)** and **Connecting Joints (No. 19)** are loose. You may remove these parts and add some lubricant oil to eliminate all noise possibilities. Remember to tighten all the parts securely.
5. If it is very hard to pedal on the higher tension levels, or you hear rubbing noises, please remove the **Left & Right Belt Covers (No. 105L & No. 105R)**, and adjust the **Hex Bolt (No. 77)** seen in the following diagram. You will need to loosen the 2 **Hex Nuts (No. 78)** and lower the position of the **Hex Bolt (No. 77)** by turning counter-clockwise. This will keep the **Magnetic Board (No. 84)** from making contact with the magnetic flywheel. Before re-installing the **Left & Right Belt Covers (No. 105L & No. 105R)**, test the tension level 8 to ensure the magnets do not touch the flywheel.

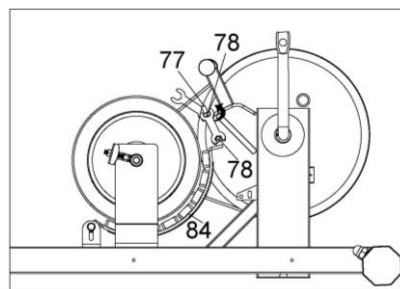

6. If you still hear noises after you did STEP 4 and STEP 5, please remove the **Left & Right Belt Covers (No. 105L & No. 105R)**. Loosen the **Hex Thin Nut (No. 87)** for the **Flywheel (No. 94)** about a half of a rotation. See the following diagram below.

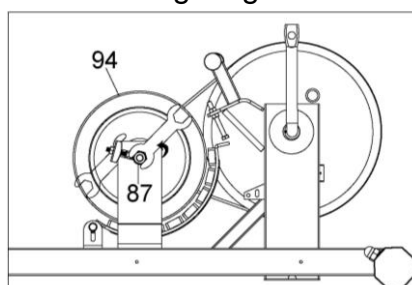

7. If the machine is wobbly when you use it, please consider adding an exercise mat under it.

ADJUSTMENT GUIDE

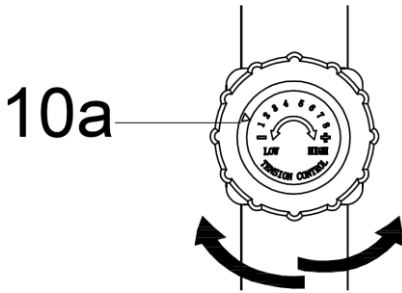
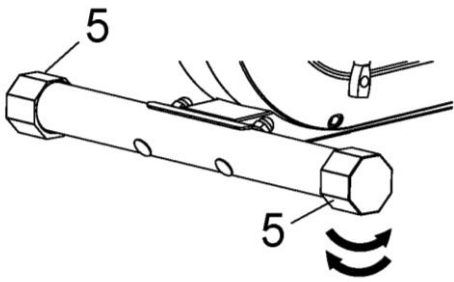
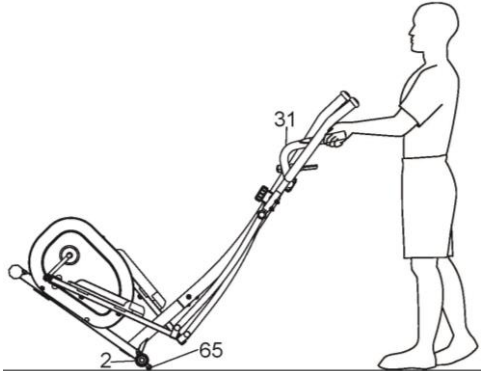
	<p>ADJUSTING THE TENSION</p> <p>Adjust the tension by rotating the Tension Controller (No. 10a) <i>clockwise</i> to increase the level of resistance. Rotate the Tension Controller (No. 10a) <i>counter-clockwise</i> to decrease the level of resistance.</p> <p>Tension levels are set at Level 1 being the lowest and Level 8 being the highest.</p>
	<p>ADJUSTING THE LEVEL</p> <p>If at any point the bike does not feel level, you can adjust the Leveler Caps (No. 5).</p>
	<p>HOW TO MOVE THE ELLIPTICAL</p> <p>There are Transportation Wheels (No. 65) located on the Front Stabilizer (No. 2). Hold the Armrest (No. 31) and push down the front of the elliptical until the Transportation Wheels (No. 65) touch the ground. Now you can move the elliptical.</p>

BATTERY INSTALLATION & REPLACEMENT

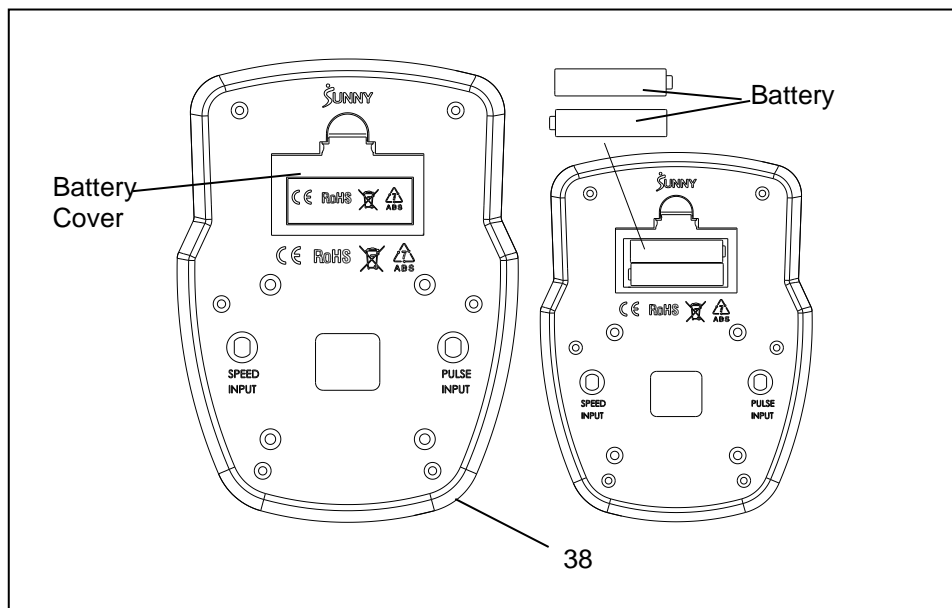

BATTERY INSTALLATION

1. Take out 2 AAA batteries from meter box.
2. Press the buckle of battery cover on the **Meter (No. 38)**, then remove battery cover.
3. Install 2 AAA batteries into the battery case on the back of the **Meter (No. 38)**. Pay attention to the battery + and – poles before installing.
4. Press the buckle of battery cover, then put the battery cover back to the back of the **Meter (No. 38)**.

The installation is complete!

BATTERY REPLACEMENT

1. Press the buckle of battery cover on the back of the **Meter (No. 38)**, then remove battery cover.
2. Remove the 2 old AAA batteries in the battery case and install 2 new AAA batteries into the battery case on the back of the **Meter (No. 38)**. Pay attention to the battery + and – poles before installing.
3. Press the buckle of battery cover, then put the battery cover back to the back of the **Meter (No. 38)**.

The replacement is complete!

BATTERY DISPOSAL

Dispose the batteries according to the laws and regulations of your local region. Some batteries may be recycled. When disposing or recycling, do not mix battery types.

EXERCISE METER

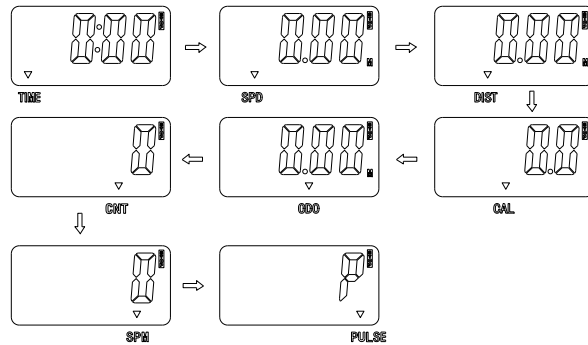
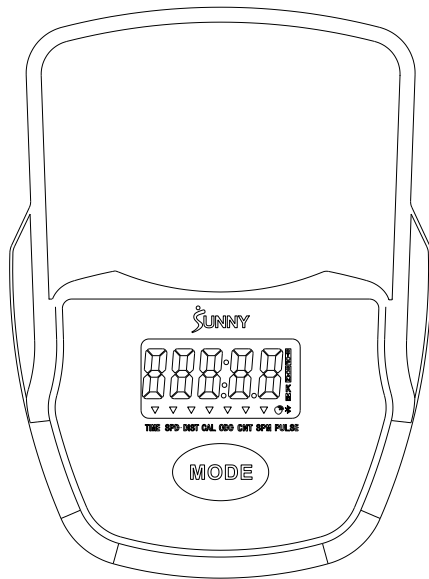

■MODE KEY FUNCTION

- This key lets you select and lock on to a particular function you want.
SCAN→TIME→SPD (SPEED)→DIST (DISTANCE)→CAL (CALORIES)→ODO (TOTAL DISTANCE)→CNT (COUNT)→SPM →PULSE
- Press and hold for 3 seconds to reset all the values, except ODO (TOTAL DISTANCE), to zero when Bluetooth is not connected.
- Press and hold for 6 seconds to disconnect from both the SunnyFit APP and the heart rate monitor; then, the meter will enter sleep mode.

■SLEEP MODE

- The meter will shut off automatically and disconnect the heart rate monitor if there is no activity or no keys are pressed for approximately 4 minutes when Bluetooth is not connected.
- The meter will turn back on when the MODE key is pressed, or there is activity.

■FUNCTION

- SCAN: Meter will rotate through all functions every 6 seconds.
- TIME: Counts the total time from start to finish.
- SPD (SPEED): Displays the current speed.
- DIST (DISTANCE): Counts the distance of an exercise from start to finish.
- CAL (CALORIES): Counts total calories burned during exercise from start to finish.
- ODO (TOTAL DISTANCE): Counts the total distance from when batteries were installed. If the batteries are replaced, the value resets to zero.
- CNT (COUNT): Displays the turns from start to finish.
- SPM: The average number of turns per minute of the wheel to measure the speed of the pedal.
- PULSE: The current pulse rate.

● BLUETOOTH

1. The Bluetooth icon will flash when the meter is on or wakes from sleep mode. If no Bluetooth connection is established within 3 minutes, the Bluetooth icon will turn off.
2. The Bluetooth icon will stay on when it is connected.

● WIRELESS HEART RATE

1. Wireless heart rate icon will flash when the meter is on. If the heart rate monitor is not connected within 1 minute, the wireless heart rate icon will turn off.
2. After exercise resumes, the wireless heart rate icon will flash. If the heart rate monitor is not connected within 1 minute, the wireless heart rate icon will turn off.

3. When the meter wakes from sleep mode, the wireless heart rate icon will flash. If the heart rate monitor is not connected within 1 minute, the wireless heart rate icon will turn off.
4. The wireless heart rate icon will flash when the MODE key is pressed. If the heart rate monitor is not connected within 1 minute, the wireless heart rate icon will turn off.
5. The wireless heart rate icon will stay on when the heart rate monitor is connected.

NOTE: The heart rate monitor is not included. Wireless heart rate function works with SunnyFit Heart Rate Monitor HR200. HR200 can only connect to the meter when the wireless heart rate icon is flashing.

■ SPECIFICATIONS

FUNCTION	SCAN	6S
	TIME	00:00-999:59 (M:S)
	SPD (SPEED)	0.00~999.99 MPH
	DIST (DISTANCE)	0.00~9999.9 MILE
	ODO (TOTAL DISTANCE)	0.00~9999.9 MILE
	CAL (CALORIES)	0.0~9999.9 CAL
	CNT	0~99999
	SPM	0~299
	PULSE	40~240 BPM
BATTERY		SIZE-AAA, 2PCS
OPERATING TEMPERATURE		0~40°C (32°F-104°F)
STORAGE TEMPERATURE		-10~60°C (14°F-140°F)

TECHNICAL DATA

Connectivity: Bluetooth LE

Frequency Range: 2400~2483.5 Mhz

Transmitting Power: 0 dBm

APP CONNECTION:

Connect Smart Equipment to SunnyFit App:

1. Scan to download SunnyFit from the app store:



2. Ensure that the Bluetooth function is turned on from your mobile device.
3. If this is your first time using the SunnyFit app, follow the in-app instructions to register for your free SunnyFit account and log in.
4. Begin any workout activity that matches your smart equipment, then follow the onscreen prompts to search for and connect to your smart equipment.
5. When connected, your stats and records will be displayed at the end of your course/session and recorded in your account profile!

Troubleshooting:

- If you are having trouble connecting your smart equipment, visit www.sunnyfit.com/guide or scan the QR code below:



- If you require additional support, please contact support@sunnyfit.com.

EXPLODED DIAGRAM 1

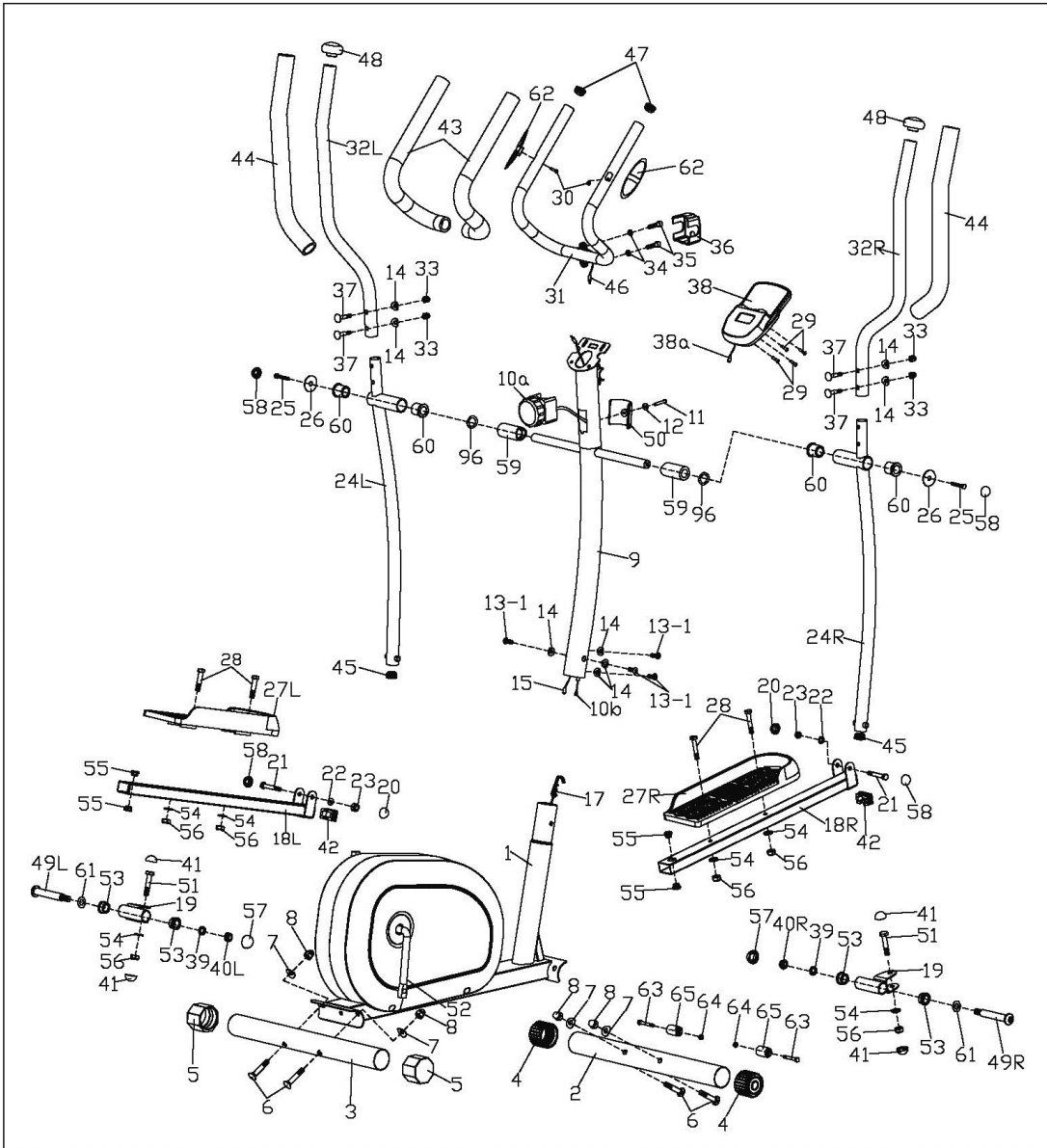

EXPLODED DIAGRAM 2

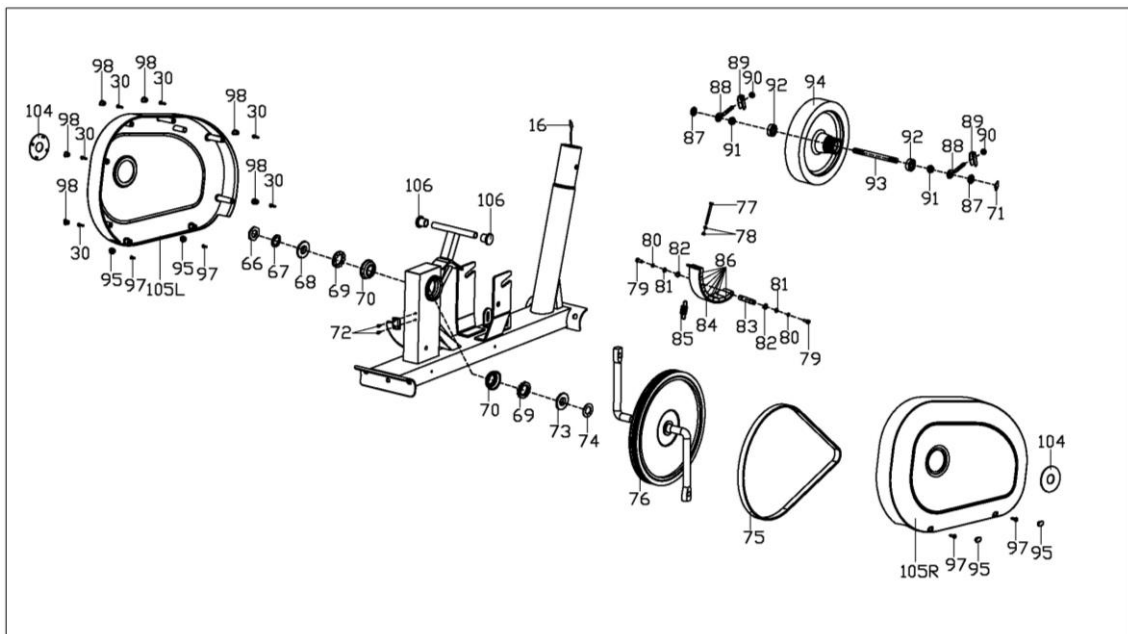

PARTS LIST

No.	Description	Spec.	Qty.
1	Main Frame		1
2	Front Stabilizer		1
3	Rear Stabilizer		1
4	End Cap	Φ50X1.5	2
5	Leveler Cap	Φ50X1.5	2
6	Carriage Bolt	M10XL57	4
7	Arc Washer	Φ10X1.5XΦ25XR28	4
8	Domed Nut	M10	4
9	Handlebar Post		1
10a	Tension Controller	8-level	1
10b	Tension Cable	L590	1
11	Phillips Screw	M5X45	1
12	Flat Washer	D5	1
13-1	Allen Bolt	M8X16	4
14	Arc Washer	Φ20XD8.5XR25	8
15	Upper Sensor Wire	900mm	1
16	Lower Sensor Wire	1200mm	1
17	Tension Hook	1300mm	1
18L	Left Pedal Support Tube		1
18R	Right Pedal Support Tube		1
19	Connecting Joint		2
20	Nut Cap	S13	2
21	Hex Bolt	M8X55	2
22	Flat Washer	D8X1.5	2
23	Nylon Nut	M8	2
24L	Left Swing Bar		1
24R	Right Swing Bar		1
25	Hex Bolt	M8X15	2
26	Flat Washer	Φ8.2XΦ32X2	2
27L	Left Pedal		1
27R	Right Pedal		1
28	Hex Bolt	M10X45	4
29	Phillips Screw	M5X10	4
30	Phillips Screw	ST4.2X18	8
31	Armrest		1
32L	Left Handlebar		1
32R	Right Handlebar		1
33	Domed Nut	M8	4
34	Spring Washer	D8X1.5	2
35	Hex Bolt	M8X30	2
36	Decorative Cover		1
37	Carriage Bolt	M8X40	4
38	Meter	BJHT060	1
38a	Meter Wire	150mm	1
39	Spring Washer	Φ13XB2	2
40L	Left Nylon Nut	B0.5X20	1
40R	Right Nylon Nut	B0.5X20	1
41	Nut Cap	S17	4
42	Square End Cap	40X25X1.5	2
43	Foam Grip	Φ23XΦ32X480	2
44	Foam Grip	Φ26XΦ36X480	2

No.	Description	Spec.	Qty.
45	Round End Cap	Φ28X1.5	2
46	Pulse Sensor Wire	600mm	2
47	Spherical Cap	Φ25X1.5	2
48	Mushroom Cap	Φ28.6X1.5	2
49L	Left Hinge Bolt	Φ16X85	1
49R	Right Hinge Bolt	Φ16X85	1
50	Tension Controller Cover		1
51	Hex Bolt	M10X50	2
52	Crank Arm	L140XW228	1
53	Axle Bushing 1	Φ24X16XΦ16.1	4
54	Flat Washer	D10X1.5	6
55	Alloy Bushing	Φ14X12.5XΦ10.1	4
56	Nylon Nut	M10	6
57	Nut Cap	S19	2
58	Nut Cap	S14	4
59	Spacer	Φ32X59	2
60	Axle Bushing 2	Φ32X2.5	4
61	Wave Washer	Φ17.1XΦ23X0.3	2
62	Pulse Sensor		2
63	Hex Bolt	M6XL45	2
64	Nylon Nut	M6	2
65	Transportation Wheel	Φ23X32XΦ6	2
66	Nut	4.5X32X32	1
67	Washer	Φ22.6XΦ28X2.5	1
68	Locking Nut-L	Φ45XH3.5XΦ33.5	1
69	Open Face Bearing	Φ45.8X8.8	2
70	Bearing Housing	∅2.5X76X76	2
71	Plastic Nut Cap	S17	1
72	Phillips Screw	ST3X10	2
73	Locking Nut-R	Φ45XH3.5XΦ33.5	1
74	Big Washer	Φ25.2XΦ38X1	1
75	Belt	380PJ6	1
76	Belt Pulley	Φ260X20	1
77	Hex Bolt	M5XL60	1
78	Hex Nut	M5	2
79	Hex Bolt	M6XL15	2
80	Spring Washer	D6	2
81	Flat Washer	D6	2
82	Axle Stop Ring	D12	2
83	Magnetic Board Axle	Φ12X50	1
84	Magnetic Board		1
85	Spring	61XΦ15XΦ1.6	1
86	Square Magnet	40X25X10	8
87	Hex Thin Nut	M10X1	2
88	Adjusting Belt Bolt	M6X50	2
89	Adjusting U Washer	3X30X20	2
90	Hex Nut	M6	2
91	Nut	M10X1.0	2
92	Bearing	6000z	2
93	Flywheel Axle	Φ10XM10X1XL118	1
94	Flywheel	Φ200X38	1

No.	Description	Spec.	Qty.
95	Belt Cover Plug		4
96	Wave Washer	Φ20XΦ28X0.6	2
97	Phillips Screw	ST5X20	4
98	Round Plug		6
99	Spanner	S13,S14	1
100	Spanner	S17,S19	1
101	Allen Wrench	S6	1

No.	Description	Spec.	Qty.
102	Allen Wrench	S8	1
103	Spanner	S13,S14,S15	1
104	Crank Cover		2
105L	Left Belt Cover		1
105R	Right Belt Cover		1
106	Plug	Φ13X1.5	2

CONNECT
with us

DOWNLOAD

Track your fitness progress & join
FREE workout courses!

Download  **SUNNYFIT** today!





FOLLOW

Find us on social media @sunnyhealthfitness

 @sunnyhealthfitness

 @sunnyhealthandfitness

 @sunnyhealthfit

 /sunnyhealthfitness

 /sunnyhealthfitness

 /sunnyhealthandfitness

www.sunnyhealthfitness.com