

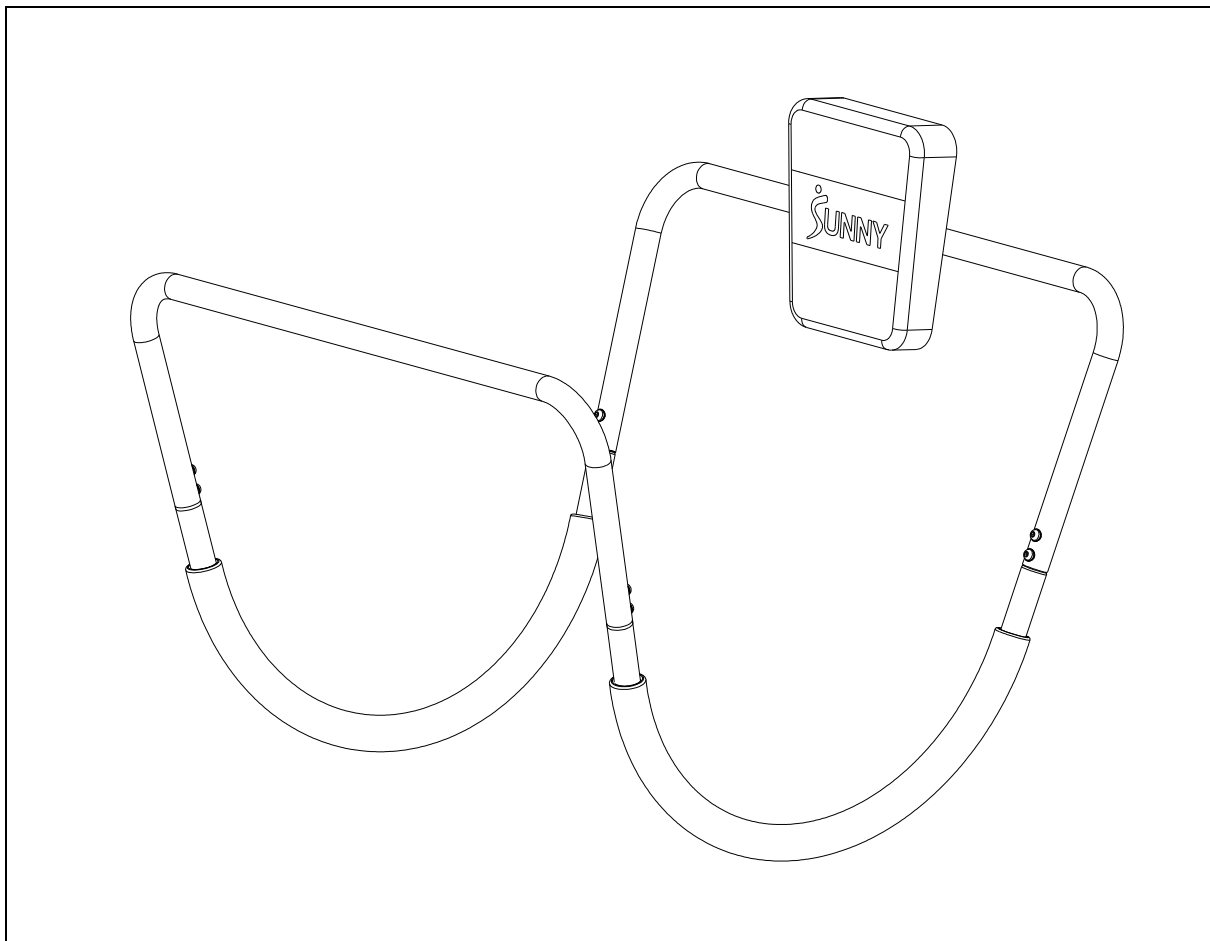

PORTABLE AB CRUNCH AND UPPER BODY ASSISTED TRAINER

SF-A023047
USER MANUAL



IMPORTANT! Please retain owner's manual for maintenance and adjustment instructions. Your satisfaction is very important to us, **PLEASE DO NOT RETURN UNTIL YOU HAVE CONTACTED US:** support@sunnyhealthfitness.com or 1- 877 - 90SUNNY (877-907-8669).



WWW.SUNNYHEALTHFITNESS.COM









IMPORTANT SAFETY INFORMATION

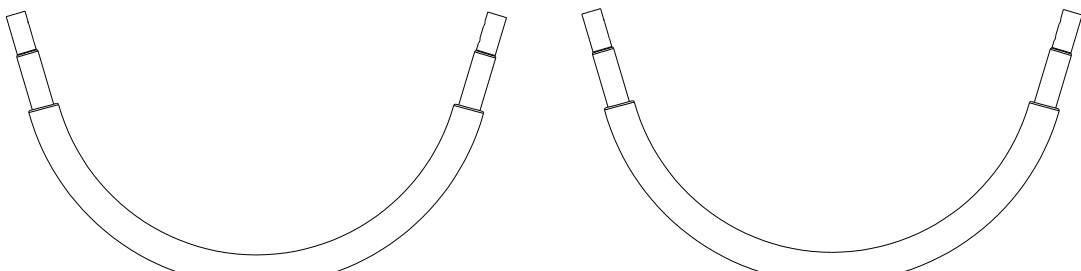

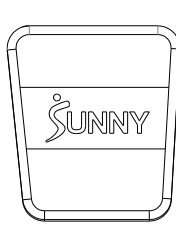
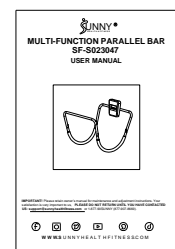
We thank you for choosing our product. To ensure your safety and health, please use this equipment correctly. It is important to read this entire manual before assembling and using the equipment. Safe and effective use can only be achieved if the equipment is assembled, maintained, and used properly. It is your responsibility to ensure that all users of the equipment are informed of all warnings and precautions.

1. Before starting any exercise program, you should consult your physician to determine if you have any medical or physical condition that could put your health and safety at risk or prevent you from using the equipment properly. Your physician's advice is essential if you are taking medication that affects your heart rate, blood pressure or cholesterol level.
2. Be aware of your body's signals. Incorrect or excessive exercise can damage your health. Stop exercising if you experience any of the following symptoms: pain, tightness in your chest, irregular heartbeat, shortness of breath, lightheadedness, dizziness, or feelings of nausea. If you do experience any of these conditions, you should consult your physician before continuing with your exercise program.
3. Keep children and pets away from the equipment. The equipment is designed for adult use only.
4. Use the equipment on a solid, flat level surface with a protective cover for your floor or carpet. To ensure safety, the equipment should have at least 2 feet (60 cm) of free space all around it.
5. Ensure that all nuts and bolts are securely tightened before using the equipment. The safety of the equipment can only be maintained if it is regularly examined for damage and/or wear and tear.
6. Always use the equipment as indicated. If you find any defective components while assembling or checking the equipment, or if you hear any unusual noises coming from the equipment during exercise, discontinue use of the equipment immediately and do not use until the problem has been rectified.
7. Wear suitable clothing while using the equipment. Avoid wearing loose clothing that may become entangled in the equipment.
8. Do not place fingers or objects into the moving parts of the equipment.
9. The maximum weight capacity of this unit is 300 lbs (135 kgs).
10. The equipment is not suitable for therapeutic use.
11. To avoid bodily injury and/or damage to the product or property, proper lifting and moving are required.
12. Your product is intended for use in cool and dry conditions. You should avoid storage in extremely cold, hot or damp areas as this may lead to corrosion and other related problems.
13. This equipment is designed for indoor and home use only; it is not intended for commercial use.

PRE-ASSEMBLY CHECK LIST

Before you start to assemble, please make sure all parts are included.

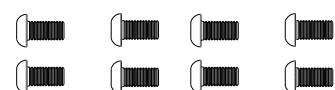
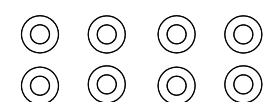
1		
 <p style="text-align: center;">#9</p>		
 <p style="text-align: center;">#6</p>	 <p style="text-align: center;">#1</p>	 <p style="text-align: center;">B</p>
 <p style="text-align: center;">#2</p>	 <p style="text-align: center;">A</p>	<p>3-1</p>  <p>#7 M6*12 S5 8PCS</p>  <p>#8 D6*Φ16*1.5 8PCS</p>  <p>#11 S5 1PC</p>

2
<p>3-1</p>  <p>#7 M6*12 S5 8PCS</p>  <p>#8 D6*Φ16*1.5 8PCS</p>  <p>#11 S5 1PC</p>

3-1

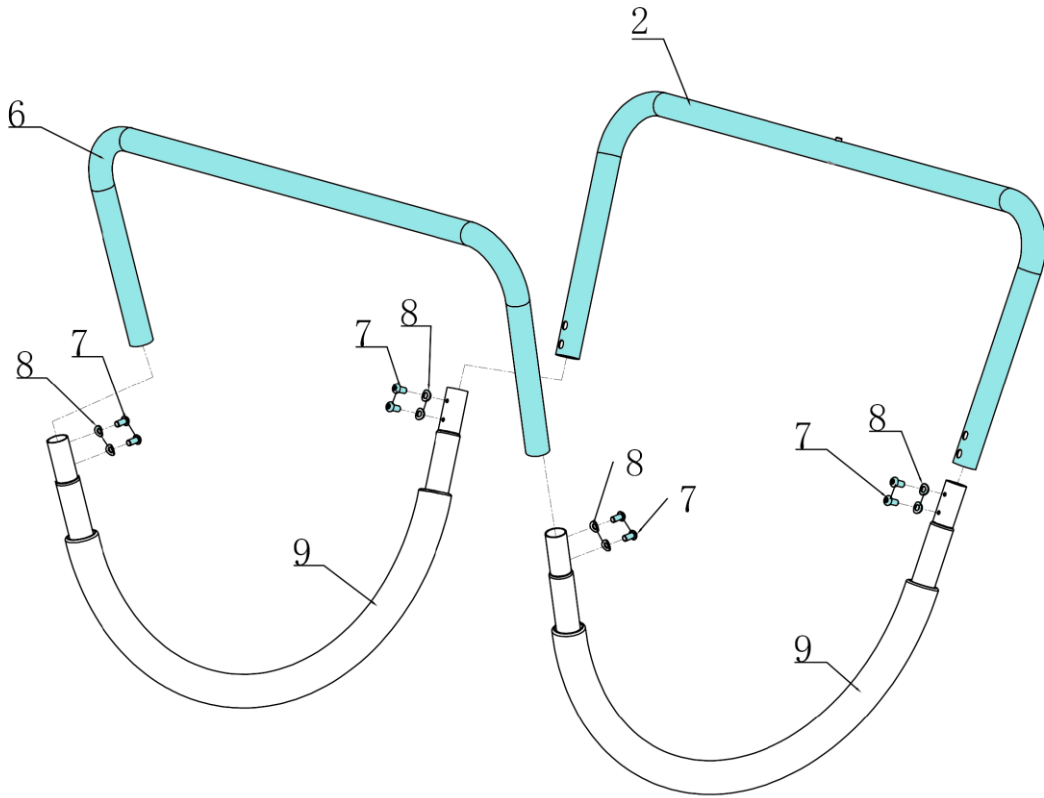

#11 S5 1PC

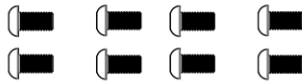

#7 M6*12 S5 8PCS

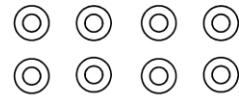

#8 D6*Φ16*1.5 8PCS

3-2

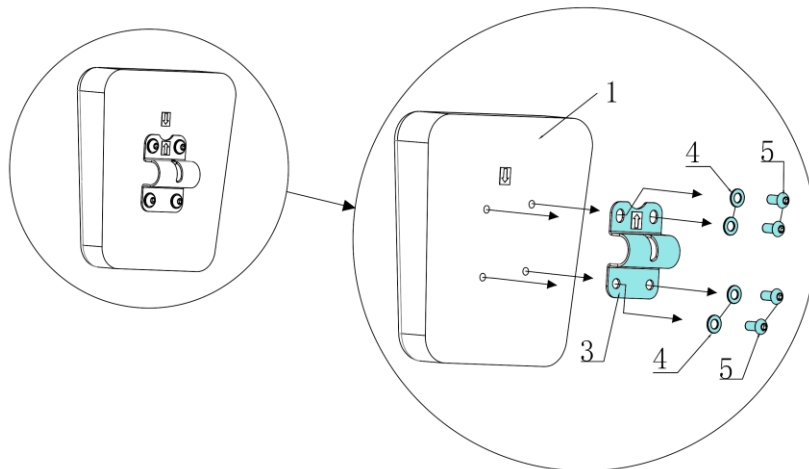

#11 S5 1PC

3-3

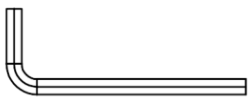
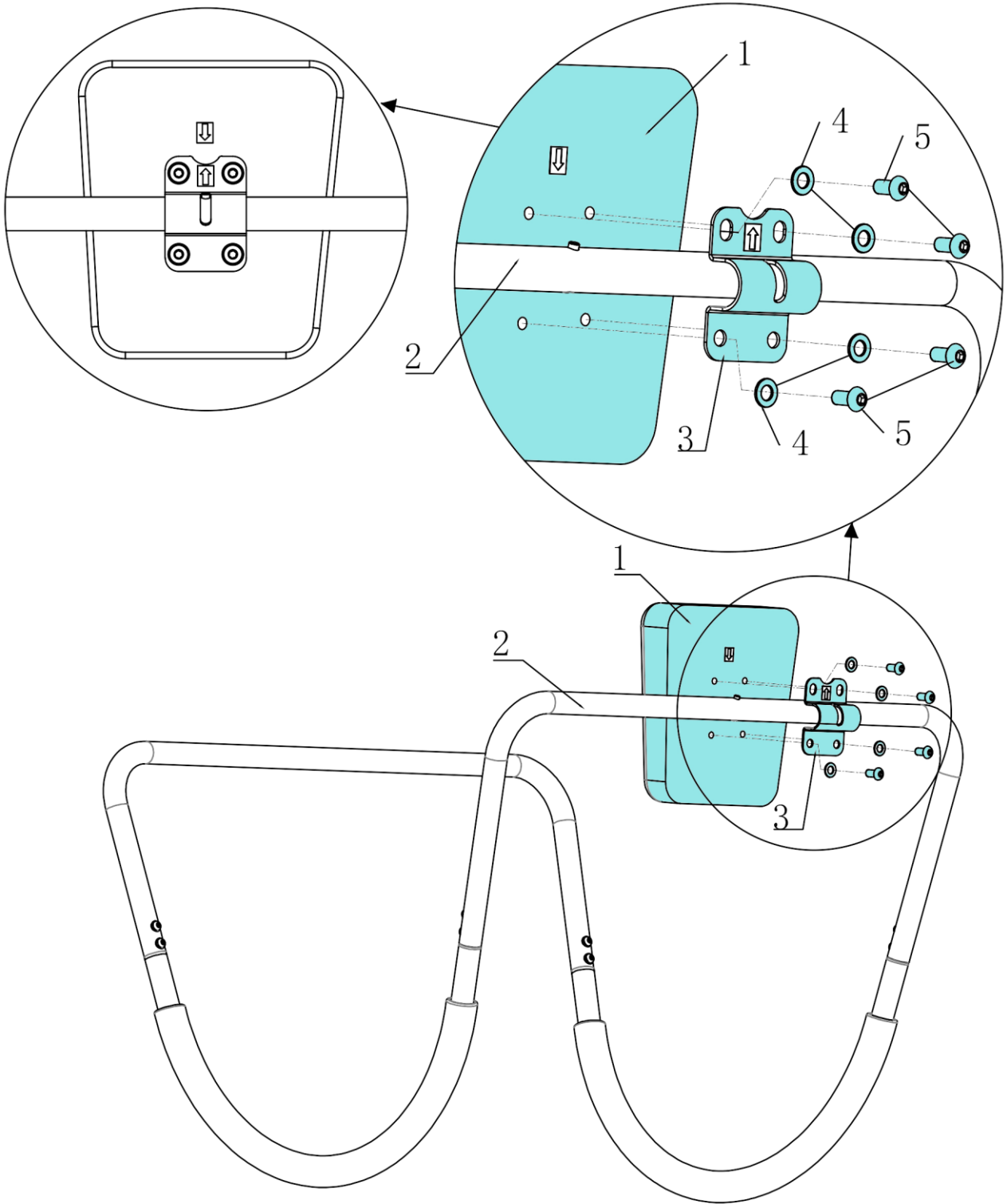

#11 S5 1PC

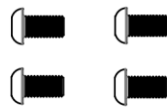

#5 M8*15 S5 4PCS

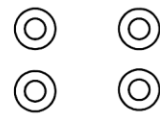

#4 D8*Φ16*1.5 4PCS

MAINTENANCE INSTRUCTIONS

DAILY MAINTENANCE

Inspect and tighten all parts regularly. (Nuts, Bolts, Rubber Pads, Steel Brackets... etc.)

Replace any worn or torn parts immediately.

Check and ensure the equipment is level at all time.

Check and tighten all adjustment pins/knobs regularly.

WEEKLY MAINTENANCE

Use damp cloth on plastic parts only, use dry cloth on metal frames.

Inspect the metal frame structure of the equipment.

DOWNLOAD SUNNYFIT - FOR HOME FITNESS



SunnyFit is an all-in-one home fitness app designed to empower users of all levels to achieve their fitness goals. Discover over 1,000 free on-demand workout video courses crafted by certified trainers, tailored for various exercise equipment such as indoor bikes, treadmills, rowers, ellipticals, dumbbells, bodyweight, and even resistance band exercises. Whether you have equipment or not, SunnyFit offers the perfect workout for every fitness level and preference. You can enjoy a collection of over 300 free workout courses that require nothing more than your body and the SunnyFit app.

EXPLODED DIAGRAM

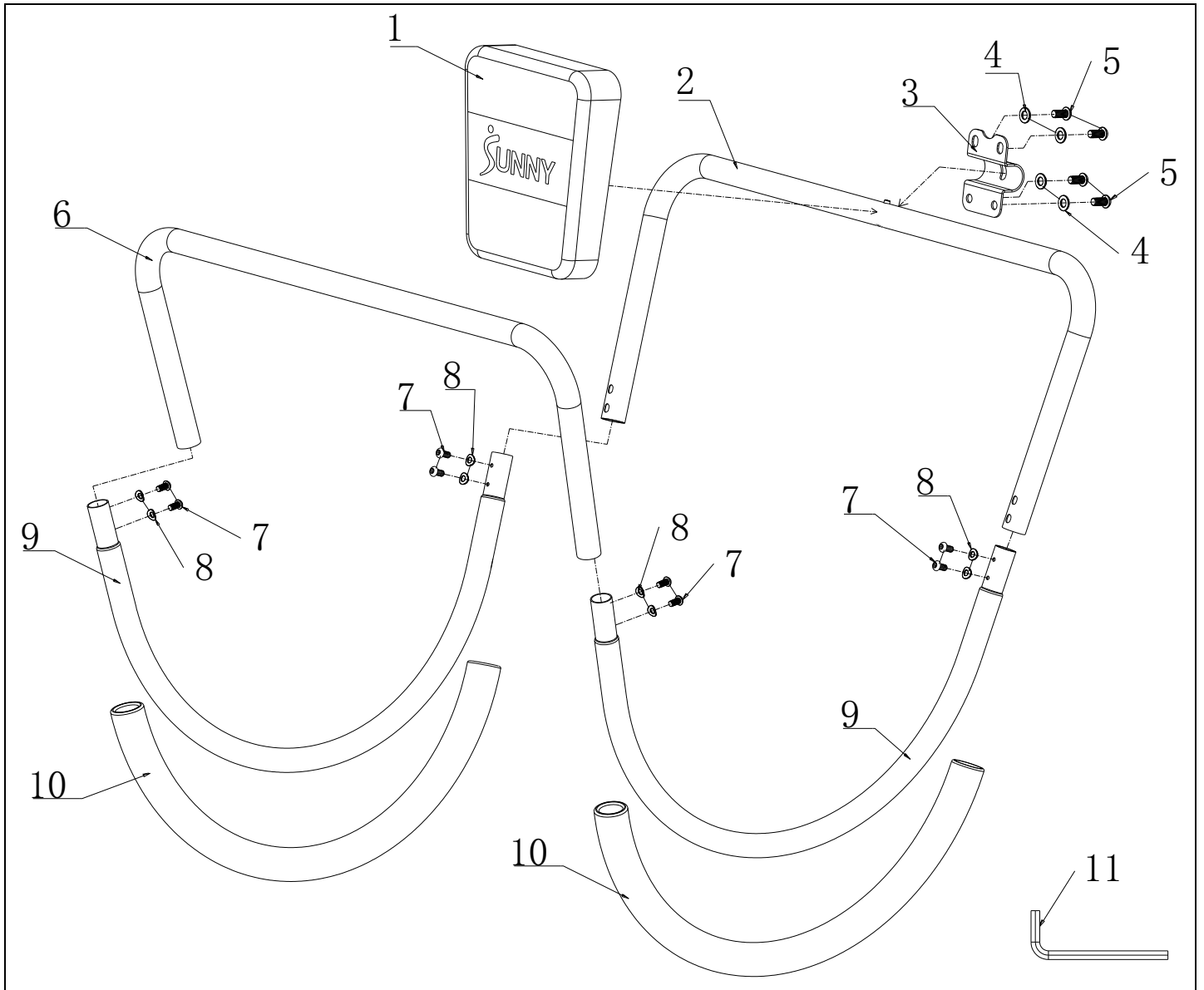

PARTS LIST

No.	Description	Spec.	Qty.	No.	Description	Spec.	Qty.
1	Head Cushion	220*200*52	1	7	Hexagon Bolt	M6*12 S5	8
2	Head Cushion Tube		1	8	Arc Washer	D6*Φ16*1.5	8
3	Head Cushion Fixing Plate	121*60*T2.0	1	9	Connecting Tube	Φ25*1.5*872	2
4	Flat Washer	D8*Φ16*1.5	4	10	Foam	Φ23*5*650	2
5	Hexagon Bolt	M8*15 S5	4	11	Allen Wrench	S5	1
6	Handrail Tube	Φ25*1.5*1092	1				

CONNECT
With us

DOWNLOAD

Track your fitness progress & join
FREE workout courses!

Download  **SUNNYFIT** today!





FOLLOW

Find us on social media @sunnyhealthfitness

 @sunnyhealthfitness

 @sunnyhealthandfitness

 @sunnyhealthfit

 /sunnyhealthfitness

 /sunnyhealthfitness

 /sunnyhealthandfitness

www.sunnyhealthfitness.com